

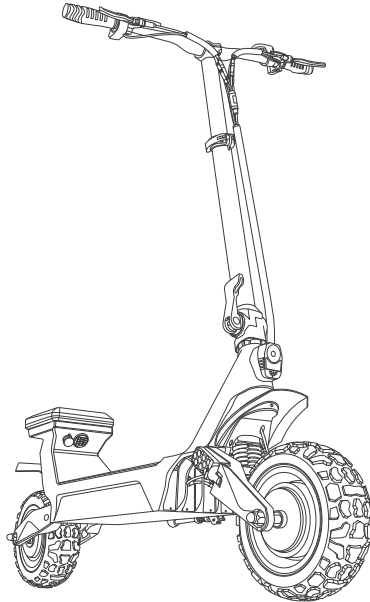

Fiido Beast Folding Electric Scooter



Dear users! Before enjoying the ride, please be sure to read the user manual carefully, understand the relevant operation specifications, and take good care of this user manual and the product certificate accompanying the ride.

Don't use the E-scooter until you fully know about the function.

Dear User:

In this manual, we will introduce you the common knowledge and maintenance requirement of electric scooter. In order to a better riding experience, please be sure to read and understand the product performance, characteristics, precautions and maintenance matters. If you have any questions, please contact the official after-sales team or local authorized service station. We will provide you with diagnostic assistance as soon as possible.

Safety Precautions

1. Please follow the precautions in this instruction to reduce risks. When you enter public areas, please obey national and local regulations, remain vigilant while riding, and maintain a reasonable safe distance from other people and vehicles.
2. Please operate by the instruction of the user manual, Fiido Beast is a recreational product. Before mastering riding skills, you need to practice. User is responsible for any injuries or damage caused by a rider's inexperience or failure to follow the instructions in this document.
3. For your first ride, please avoid any area with many children, pedestrians, pets, vehicles, or other obstacles and potential hazards.
4. Before each ride, please ensure all the fasteners are not loose, and parts are not damaged. If there's any unusual noise, please stop riding immediately, and contact after-sales team for assist.
5. To reduce the injury risk, please read and follow all "Caution", "Danger" and "Warning" instructions in this user manual. Do not speed, and do not ride in motorized road under any circumstances.
6. For safety consideration, user must be over 16 years old. Users under the following circumstances are strongly not recommended to use this product.
 - People affected by alcohol or drugs.
 - People who are unable to engage in strenuous physical activity due to illness.
 - People who are unable to maintain balance or whose balance is impaired by motor skills.
 - People whose weight exceeds the max load limit (max load is 120KG/265lb).
 - Pregnant women.

7. Please ride carefully in snow, rain, wet road, ice and other bad weather. Do not ride over too high or too large obstacles, otherwise it's very likely to lose balance or grip and cause injuries.
8. Do not attempt to charge while the charger or power supply is wet, please follow the local safety regulations if you need to charge the E-scooter in public area.
9. Only use original parts from Fiido.
10. Any engineering/structure modifications to the product will void the warranty.
11. For safe disposal of used batteries and leaking batteries, dispose these batteries as unsorted municipal waste. Please contact your local municipality for the nearest collection point.

STORAGE

1. Store the lithium battery in a place away from the fire source, the ambient temperature is about 20, ventilated and dry without debris, not in a damp place to avoid leakage and short circuit.
2. Keep away from direct sunlight.
3. Do not hit, squeeze, throw, needle or tread on the battery.
4. If the battery voltage is lower than 3.6V for a long time, the battery will overdischarge and damage the internal structure of the battery, reducing the battery life. Therefore, it is recommended to charge once every 1 month, and the best storage voltage of lithium battery is about 3.85V, which is not good for storage and full storage.

DISPOSAL

1. Do not discard the battery after the vehicle is abandoned to prevent environmental pollution
2. Contact manufacturers or professional institutions for professional treatment of the battery.
Do not disassemble or destroy the battery by yourself, so as to avoid danger
3. Generally, batteries cannot be sent by ordinary express in case of battery fire or explosion caused by collision during transportation. If batteries are recycled, please contact professional transportation agencies

CONTENTS

1. Product introduction

- 1.1 Product overview
- 1.2 Packing list
- 1.3 Product diagrams
- 1.4 Function description

2. User guide

- 2.1 Installation guide
- 2.2 First ride
- 2.3 keyless security system
- 2.4 Charging instructions
- 2.5 Folding instructions

3. Maintenance precautions

- 3.1 Precautions
- 3.2 Scooter maintenance & repair
- 3.3 Motor maintenance & repair
- 3.4 Controller maintenance & repair
- 3.5 Battery maintenance & repair

4. Service directory

- 4.1 Troubleshooting methods
- 4.2 Specifications
- 4.3 Warranty coverage
- 4.4 Repair record

* All pictures are for reference only.

1. Product introduction

1.1 Product overview

1.2 Packing list

1.3 Product diagrams

1.4 Function description

1.1 Product overview

Fiido Beast is a new type of electric scooter. Following Fiido's consistent minimalist design aesthetics, it's ingeniously designed to achieve a dual-use, multi-functional experience. It is the perfect combination of electric scooter and go-kart. No matter for city commuting or off-road riding, it's easy to ride for both use. Fiido Beast redefines the riding way and use scenario of electric scooter.

Fiido Beast has a magnesium alloy frame and aluminum alloy fork arm , 90/65-6.5 specialty off-road tires and a strong shock absorption system. Rear/dual driving force mode can be switched freely, and a 48V large capacity battery provides a powerful backing guarantee for the battery life. Equipped with Fiido's unique keyless security system, it has the professional protection for vehicle security. Foldable riser can be adjusted into different height to fit different user.

1.2 Packing list

Scooter parts

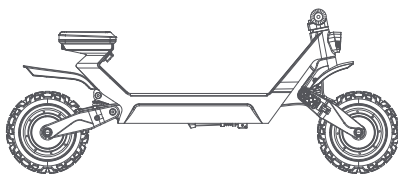

Scooter*1



Stem*1



Riser*1



Handlebar*1

Accessories



Charger*1



User manual card*1



Magic strap*1

Tools



Y-Type Allen Wrench*1

*Please carefully check whether all items are complete and intact. If there is any problem such as missing or damaged parts, please contact the official after-sales team immediately.

1.3 Product diagrams

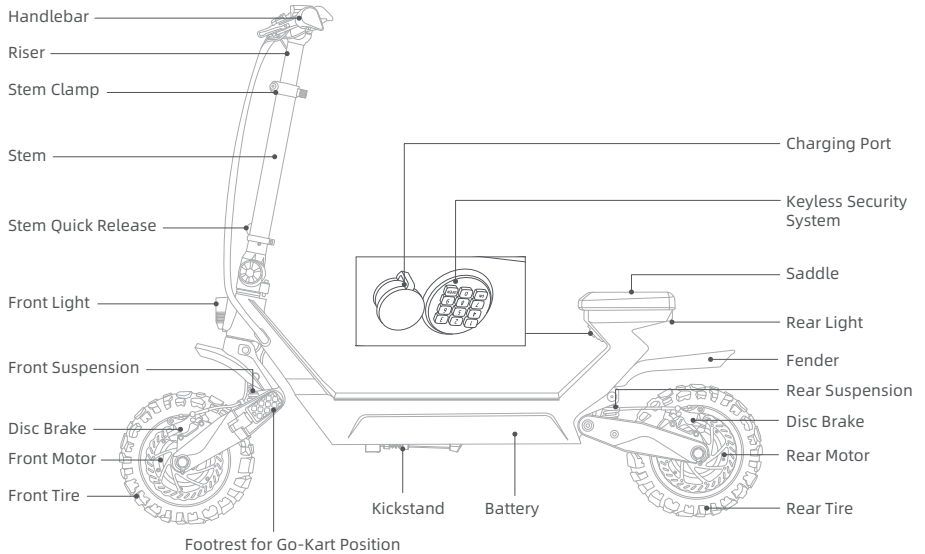

*Non professionals are forbidden to disassemble and assemble the battery. Please contact after-sales team for assist.

1.4 Function descriptions

Handlebar

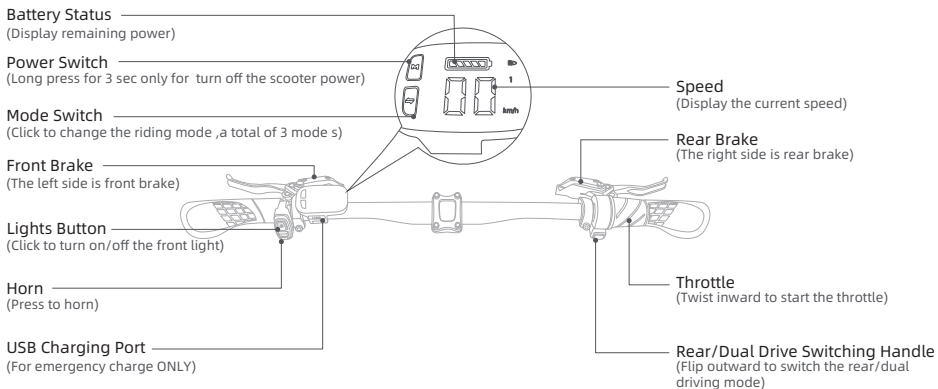

Battery

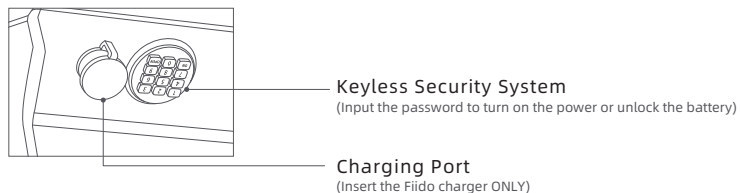

2. User guide

2.1 Installation guide

2.2 First ride

2.3 Keyless security system

2.4 Charging instructions

2.5 Folding instructions

2.1 Installation guide

The basic installation of the E-scooter has been completed before leaving the factory. After receiving the scooter, you only need to unfold the stem and assemble the handle bar.

Install the stem

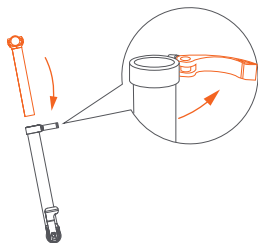

① Take out the stem and riser from the accessories kit, open the stem clamp, insert the riser to the bottom of the stem.

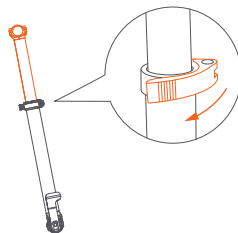

② Then close the stem clamp.

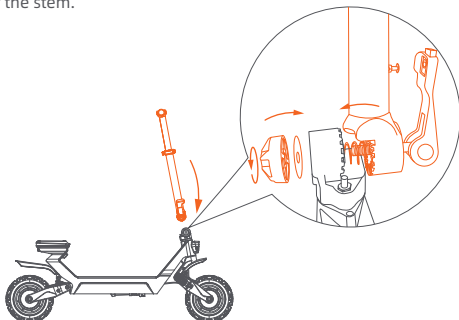

③ Take out the spring of the accessory box, put it inside the side of the stem bottom, the side with the clamp slot, then align it with the front clamp slot and buckle it. Align the stem quick release with the slot free side, pass it through the bottom connection of the stem. After placing the gasket on the other side, place the stem adjusting nut.

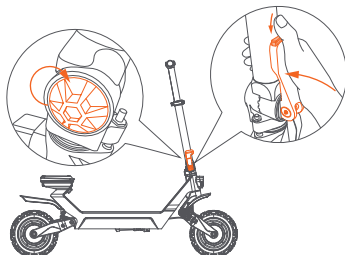

④ Tighten it with the stem adjusting nut to secure the connection between the stem quick release and the stem. Close the stem quick release to complete the installation of the stem.

(Caution: Please make sure the stem is tightened and stem quick release is in closed status, otherwise there are security risks.)

Install the handlebar

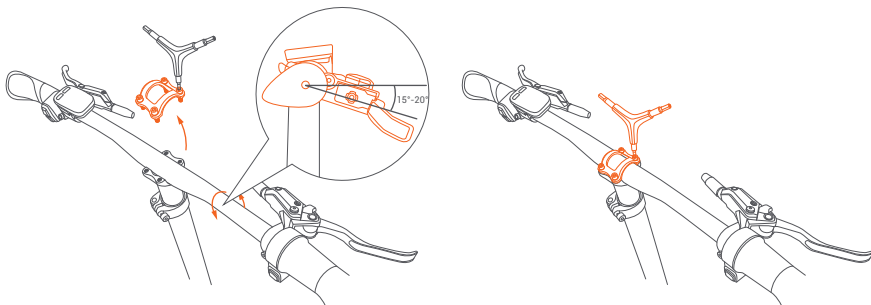

① Remove the handlebar screws, hang the handlebar and keep the center of the handlebar in the stem, then adjust the handlebar direction so that the brake level is in the direction of 15°~20° with the horizontal line. Then fasten the riser cover and lock the screws evenly.

(Cautions: When locking the riser cover marked in orange on the above picture, keep the gap on both sides even, and lock the four screws until the handlebar is tight in place. If this step is not performed properly, there will be a risk of loosening during use.)

② Using the hex wrench in the packing case, twist the four screws into holes on the top of handlebars and lock them tightly (install two screws on each side), then the handlebar installation is completed.

(Cautions: Tighten the four screws gradually. Do not tighten one screw all the way.)

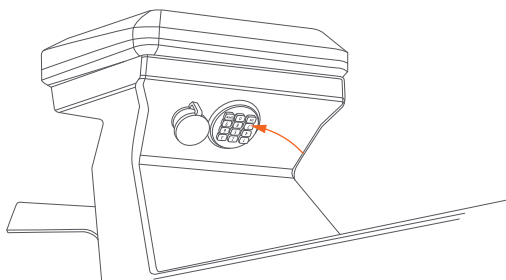

③ After the handlebar is installed, the power supply of the scooter can be turned on and off for testing. (Please refer to P12 for specific power startup steps)

2.2 First ride

Before first ride, please follow the installation guide to install components properly, check all the screws are well tightened, ensure sufficient power and wear protective gears.

Step 1: Adjust the stem

Please check whether the handlebar quick-release screw is tightened whether the handlebar angle is 90° with the stem.

(Cautions: Please make sure the stem is tightened and stem quick release is in closed status, otherwise there are security risks.)

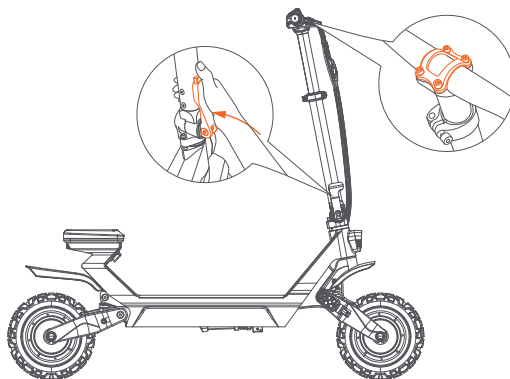

Step 2: Turn on the power

Input the six-digit password then click the power button, to turn on the scooter power. (more detail please check P-12) .

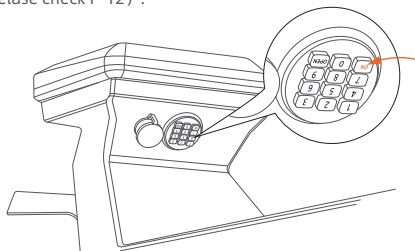

Step 3: Usage method

E-Scooter mode or go-kart mode can be selected according to the cycling road conditions and user's own needs.

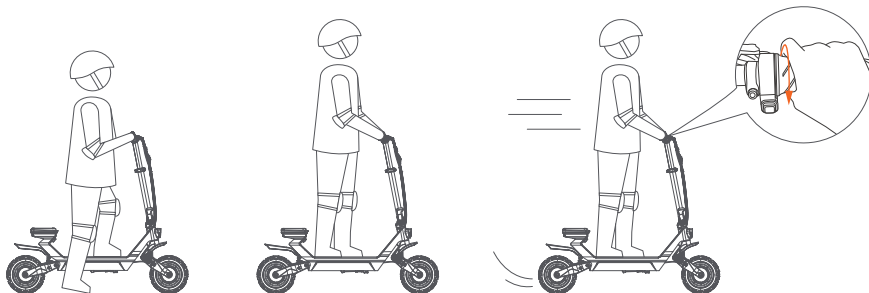

① E-Scooter mode: Stand on the deck with one foot, push back on the ground with the other foot, start sliding. Then put the other foot on the deck, keep the balance, twist the right throttle for acceleration.

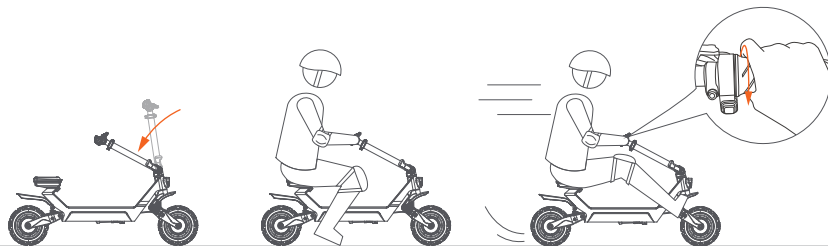

② Go-kart mode: adjusting the stem downward to a proper angle, sit firmly on the saddle, push back to the ground with both feet, and start sliding. Keeping the balance, and twist the right throttle to accelerate while you can place your foot on the deck or footrest.

(Cautions: For your safety, the motor will not start until the scooter reaches 1.8 MPH /h(3km/h). When in use, it is not recommended to use karting mode for turning.)

(Cautions: The magic strap can be used for main cables organization while riding in Go-kart mode, otherwise the main cables may hook with branch or other obstacle, to cause the rollover risk.)

Step 4: Mode choosing

① Gear switch: Before starting riding, please choose gear 1 for the safety consideration, later you can switch the gear according to the cycling road conditions and your own needs.

Gear 1 is the ECO mode, which provides lower power/speed (1-15km/h)

Gear 2 is the standard mode, which provides medium power/speed (1-20km/h)

Gear 3 is the sport mode, which provides stronger power/speed (1-25km/h)

② Drive switch: The scooter automatically defaults to rear motor drive mode. During riding, you can press the rear/dual drive motor button in the throttle to switch the mode according to the riding road conditions or your own requirements.

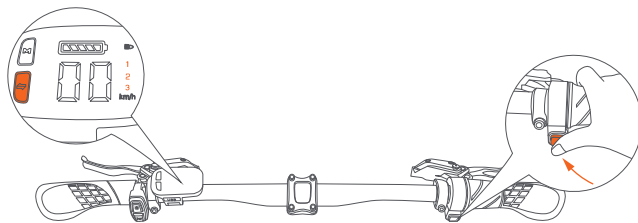

Step 5: Braking introduction

The left side is front brake, the right side is rear brake. While riding, it's recommended to use the rear brake first, then the front brake to slow down the speed to stop, Do not abruptly brake on the front brake, as this could cause the scooter to topple and crash.

(Caution:Lean your weight towards the turning direction and slow down the speed .)

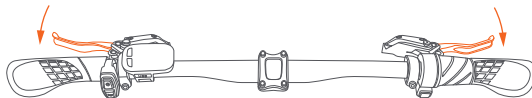

2.3 Keyless security system

The original password is “012345” . Once the afferent password includes 012345, the coded lock may be able to turned on. Therefore we strongly suggest that after receiving the scooter, please customize the password as soon as possible.Please follow the following steps:

Password modification steps

1. Start the power: Input the original password “012345” + “ON” , to start the E-scooter power.
2. Change the password:
 - ① Press “ON” + “OPEN” at the same time for 4 sec.
 - ② Input the original password “012345” + “ON” , then input the new six-digit password “*****” + “OPEN” to finish the password modification.

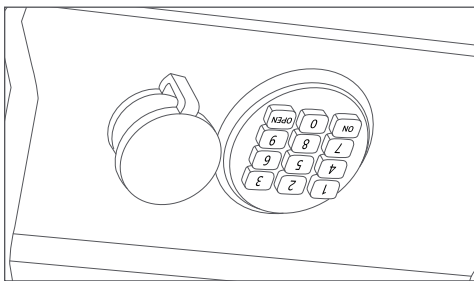

Caution:

- ① You will hear a long beep if the password change is successful.
- ② If you hear 3 short beeps, you may need to repeat the above steps, or contact the after-sales team by sending the operation video.

The password is used to turn on the E-scooter power, and remove the battery. Please follow the following steps:

Turn on power

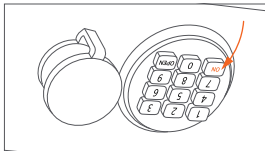

1. Input six-digit password, then click the "ON" to start the E-scooter power.



2. When the power supply starts successfully, there will be a long beep. If the startup fails, there will be two short beeps. In this case, you need to re-enter the correct password to enable the startup.

How to remove the battery

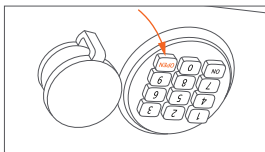

1. Input six-digit password, then click the "OPEN". With long beep means unlocking the battery is successful.

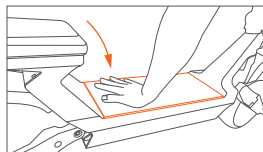

2. Press the rear part of the battery cover, the cover will pop up and open.

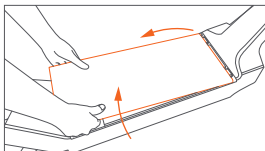

3. When the rear battery cover plate is up to a certain angle, pull the battery cover backward, then remove the battery cover and separate it from the E-scooter.

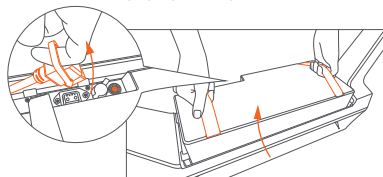

4. Press the button on the battery to turn the battery off, and remove the power supply port. Pull both belts on the battery with both hands to remove it.

2.4 Charging instructions

The battery comes with a small amount of electricity, before the first time use, please make sure to charge it to full power before riding.

Charging

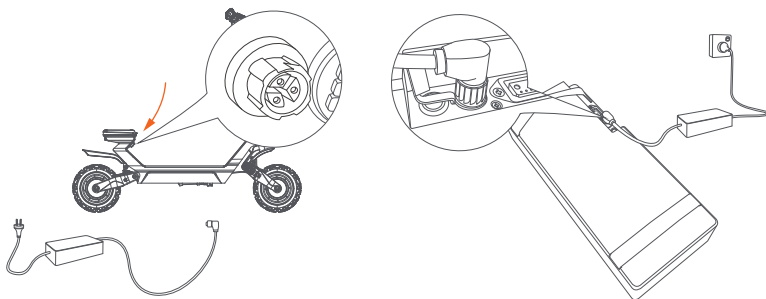

1. Charging connection: Connect the charging interface to the charging port, then connect the power plug to the power socket.
2. Fully charged: When the indicator light of the charger is red, means it's normal charging. When the light is green, means it's fully charged.
3. Charging time: Charging time is around 13 hours, The duration depends on the situation.
4. Disconnect charging: When the indicator light turns green, means it's fully charged. Slightly switch the safety lock, then unplug the power plug, then remove the charging interface from the battery. Close the battery cover.
5. Charging ways: The E-scooter supports two charging ways: Charging directly or taking out the battery to charge. Please see P13 for how to remove the battery.

Caution: Charger has high voltage, **DO NOT** repair without permission. In order to avoid danger, battery and charger should be placed away from children, inflammable and explosive objects (such as car seat cushions, sofas, etc.). Keep the battery in a ventilated and dry place, and make sure **NOT** to charge in open-air place to avoid electrical short circuit fire and other accidents caused by rain and other factors. And to prevent liquid and metal particles from entering the electrical parts.

Danger: Charging can be allowed to use public charging equipment, but the matching between the battery and the charging equipment should be fully considered.

Warning: If there's any odor or high temperature during charging, please stop charging immediately and contact after-sales team for assist.

2.5 Folding instructions

Fold the stem

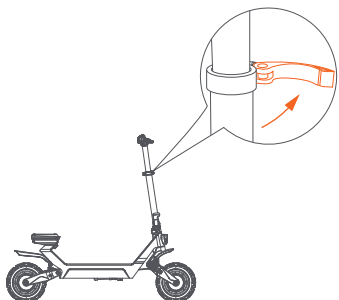

① Open the stem clamp.

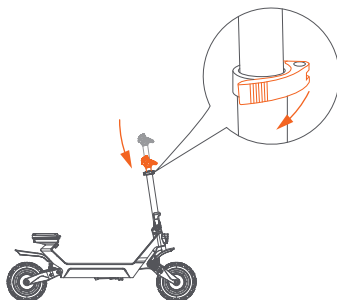

② Lower the riser downward to the end, then close the clamp.

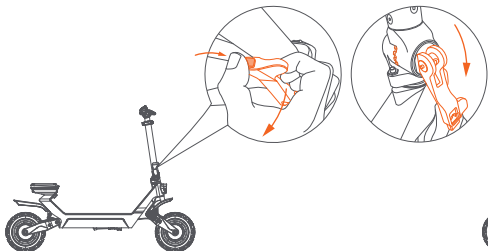

③ Press the safety hook, open the stem quick release and keep it in open status.

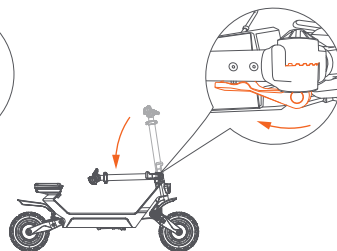

④ Gently turn the stem downward to the end to finish the stem folding. The gear of the stem need to be matched perfectly to close the stem quick release successfully.

3. Maintenance precautions

3.1 Precautions

3.2 Scooter maintenance & repair

3.3 Motor maintenance & repair

3.4 Controller maintenance & repair

3.5 Battery maintenance & repair

3.1 Precautions

(3.1.1) Users should pay attention to the safety of scooter use

1. No parking in building foyers, evacuation stairs, walkways and safety exits.
 2. No charging in residential buildings. Charging should be far away from combustible, and no longer than 15 hours.
 3. Prevent water from entering electrical parts. When cleaning the bike, avoid water impact on charging port, wiring harness connectors, fuse and other electrical parts.
 4. When adjusting the height of the riser, the safety line mark of the riser should not be exposed.
 5. Users and dealers must not rewire and modifying structure and performance without permission. Such as: change the battery configuration, the circuit, increase the lamp power, increase the sound and other modification.
 6. Do not touch the circuit part of the E-scooter with wet hands or metal conductors. Such as: charging port, charger plug etc.
 7. Please do not disassemble electrical parts without authorization to prevent liquid and metal particles from infiltrating into electrical parts.
 8. Do not ride in bad weathers, or place the E-scooter in a long-term exposure to the sun/rain to avoid parts aging.
 9. If cleaning is needed, please wipe the body with a neutral lotion mixed with tap water. Do not remove and wash internal parts to avoid short circuit.
 10. Devices are not intended for use at elevations greater than 2000m above sea level
 11. Prolonged Exposure to UV Rays, Rain and the Elements May Damage the Enclosure Materials, Store Indoors When Not in Use
 12. WARNING - Risk of Fire - No User Serviceable Parts
- Caution: Non-professionals are strictly prohibited to repair. In case of failure, please contact the after-sales team or authorized professional maintenance station for maintenance.**

(3.1.2) Riding safety: please follow the national and local traffic laws and regulations, pay attention to riding safety.

1. User must be over 16 years old. Do not lend to people who can not operate the scooter to avoid the harm.
2. Please ride in Non-Motor Vehicle Lane, with the max speed no more than 25km/h.
3. Please DO NOT carry person or goods while riding.
4. Please be sure to wear a suitable safety helmet and fasten the helmet wind strap while riding.
5. The braking distance will be extended in rainy and snowy days, please pay attention to slow down, and try to avoid to ride on bad weathers. Inner short circuit and electrical parts damage may be caused if the water level reaches the center of the hub of the rear wheel motor, please noticed.
6. Please follow the local traffic rules carefully. No riding after drinking, and make sure riding with both hands.
7. Do not hang heavy objects on the handlebars.
8. Do not ride with one foot, in groups or with children in your arms. It is forbidden to turn handlebars sharply when driving at high speed. This can cause injuries.
9. Bright colors, casual, comfortable wears and low-heeled shoes are suggested for riding.

(3.1.3) Examination before riding: please repair in time or go to the local maintenance point for repair, if there's any abnormality.

1. Turn on the power, check the indicator light is normal, and the power supply is sufficient.
2. To confirm the normal power use, please lift the rear wheel make it off the ground(under the rear drive motor status).
3. Check the horn and front/rear lights are in good condition.
4. Confirm whether the handlebar and stem are adjusted to the appropriate position, then fastening screws and quick release . Pay attention that the safety line should not be exposed.
5. Check the front/rear brake handle ensure the brakes are functional.
6. Check whether the tire pressure is normal, no cracking, abnormal wear, nails, stones, glass and other sharp objects.
7. Check whether the front/rear wheel screws are fastened.
8. Check whether the front /rear lighting is normal and ensure that lights can be good used while riding.
9. Check the fastening state of each axle to ensure the front/rear axles are in a reliable state.
10. Check whether the stem clamp and quick release are locked before riding.

Caution: Abnormal tire pressure, tire cracking damage and abnormal wear are the main causes of steering failure and tire burst.

(3.1.4) Attention on the road

1. For your safety and the safety of others, please obey the local traffic rules conscientiously.
2. Before riding, be sure to wear a safety helmet, take safety precautions and maintain a natural posture.
3. At the beginning of riding, please slowly accelerate, to avoid the energy waste or accidents. For a longer service life of the battery and motor, when start riding , please try to use gear 1.
4. To ensure safety, gear1 should be used as far as possible, and reduce frequent braking and start as far as possible to save electricity.
5. Do not ride in high speed on muddy areas or uneven roads . User should push the scooter forward for safety consideration.
6. Braking distance should be appropriately increased on bad weathers, please be vigilant while ride.
7. Use gear 1 when going up hills or against strong wind. The scooter is equipped with overcurrent protection. The circuit may be overcurrent under the condition of higher uphill Angle and higher headwind speed. Power consumption may be too fast to affect the range, motor and electrical appliances burn. The body and electrical parts should not be electriferous, the insulation resistance value shall not be less than 2MΩ.
8. Controller has undervoltage protection, the power will be cut off automatically if the voltage is lower than the undervoltage value to maintain the service life of the battery.

(3.1.5) Attention of pushing and parking

1. Turn off the power when pushing the E-scooter to avoid the accidents.
2. Parking should be on the level ground and maintain the E-scooter as power off status.
3. For your safety, please maintain and clean your E-scooter regularly to keep it in the best condition.

3.2 Scooter maintenance & repair

1. The scooter has been adjusted well before leaving the factory. Please contact after-sales team if there's any problems.
2. Make sure tire pressure in normal condition -350kPa(50psi) .
3. Make sure the main parts like handlebar, stem, saddle, front/rear lights and brakes , axle, wheels are in normal use, nut and screw are tightened .
4. If the vulnerable parts are damaged, such as: brake line, brake skin, brake pad, lights, etc. Please find the local maintenance center to replace but be sure to replace with the same model specifications of the parts.

Cautions: Handlebar core screw fastening torque, combined handlebar joint screw fastening torque, front wheel fastening torque recommended torque is not less than 25NM;The recommended torque for fastening the central shaft lock mother and rear wheel is not less than 30NM. Stem safety line should not be exposed outside the body.

3.3 Motor maintenance & repair

1. Equipped with rare earth permanent magnet DC brushless, external rotor hub motor, without carbon brush, which is basically maintenance-free.
2. Do not open the motor base and end cover after sealing.
3. Keep the motor clean, no foreign matter, corrosive liquid and gas insert into the motor. Do not knock and bake the motor shell, so as not to damage the motor.

Caution: If there's any damage that affects the E-scooter function , please consult after-sales team.

3.4 Controller maintenance & repair

1. The controller with intelligent digital chip, brake power off, battery undercurrent voltage protection, over current protection, non-zero start power control and other functions.
2. The controller is waterproof, shockproof, anti-corrosion, tamper-proof and other functions. It adopts epoxy or polyurethane packaging process. If there is a fault, please do not disassemble it for maintenance without approval, but return it to the factory for maintenance by professional technicians. If it is just simple connector loose, users can solve it by themselves.

Cautions: If there's any damage that affects the E-scooter function , please consult after-sales team.

3.5 Battery maintenance & repair

1. Battery life is closely related to how you use the scooter. Frequently charge the battery when not in use.
2. It is recommended to charge for 13 hours each time, and the longest time is not more than 15 hours. Lithium battery has no memory function, can be charged under any battery power capacity.
3. Make sure to charge for more than two hours every month when not in use . Do not store the battery at low power for long period time which will cause the battery capacity.

Danger: Do not dismantle used battery without authorization, it should be collected according to regulations.
Warning: Do not near the fire or high temperature source, or throw it into the fire and expose it to the sun.

4. Service directory

4.1 Troubleshooting methods

4.2 Specifications

4.3 Warranty coverage

4.4 Repair record

4.1 Troubleshooting methods

Fault code description

Fault code	Fault phenomenon
E1	Communication issues
E2	Throttle issues
E3	Brake lever issues
E4	Motor hall issues
E5	Motor issues
E6	Controller issues

General fault

Fault phenomenon	Fault cause	Rule out way
Through-supply motor failure	Poor contact of regulating handlebar Poor contact of brake cut-off switch Motor damage Controller damage Loosened connector	Change regulating handlebar Change brake cut-off switch Change motor Change controller or get repair Check the connector
Lack of range	Tire pressure deficiency Undercharged or faulted charger Aging battery or damaged battery More uphill, Gale, frequent braking, Overload, Etc	Blow up the tire Fully charged, check charger Change battery Using pendal mode
Difficulty in charging	Loosened plug Disconnected battery cable Damaged charger	Tighten socket and connector Welded connector Change charger
Speed failure or low speed than 10KM/h	Poor contact of regulating handlebar Loosened connector Battery overvoltage	Change regulating handlebar Check the connector Fully charged

4.2 Specifications

Property index	Item	Fiido Beast
Product size	Before folding: Length*Width*Height (mm)	1310*710*1200
	After folding: Length*Width*Height (mm)	1310*710*570
	Tires	90/65-6.5
Product weight	Net weight (kg)	37.5
Riding requirement	Maximum load (kg)	120
	Applicable age	16+
	Applicable height	155cm(5.0') - 200cm(6.5')
Main spec	Serial numbe Location	Under the frame
	Maximum speed	15MPH (25km/h)
	Maximum climb	35-40% (20-22°)
	Center distance between wheels (mm)	1036
	Applicable road	Urban asphalt pavement/flat pavement/Off-road
	Operating temperature	-10° ~50°
Battery	Rated voltage (V)	48
	Battery type	Lithium battery
	Rated capacity (Wh)	1536
	Battery management system	Overheat/short circuit/overcurrent and overcharge protection
	charging temperature	0-50°C
	The discharging temperature	10-45°C
	Storage temperature	10-45°C

Motor	Rated power (W)	F500, R800
	Rated speed (r/min)	900
	Moter type	Brushless gearless motor
Controller	Undervoltage protection (V)	40±1
	Overcurrent protection (A)	F18, R24
Charger	Input voltage (V)	100-240
	Output voltage (V)	54.6
	Output current (A)	3
	Charging hours (h)	13
	Model	LBC100201
	Manufacturer	SHENZHEN ATEN TECHNOLOGY CO.,LTD
Others	Front light	LED
	Tail light	LED
	Riding mode	E-scooter mode+Go-kart mode

Caution :

*The above data allow for 5% manufacturing tolerances.

*After receiving the E-scooter, there may be some differences between individual accessories and display drawings, which are different due to the different batches, and do not affect the use.

4.3 Warranty coverage

(4.3.1) What does this warranty cover?

This warranty covers any defects in material or workmanship under normal use during the "Warranty Period". Warranty does not cover tyres, tubes, brake pads or chains.

(4.3.2) Warranty scope and period

Item	Parts	Guarantee time	Service
Basic parts	Frame	12 months	Natural deformation, desoldering fracture phenomenon, quality problems caused by poor manufacturing can be replaced. Self-modification, collision damage, etc. are not warranted.
	Fork, Handlebar, Stem	12 months	
	Kickstand, Saddles, Fenders, Safety hook, Stem clamp, Frame clamp, Footrest, Brake discs, Brake levers	12 months	Tire puncture by sharp objects, collision damage of spare parts, etc. are not warranted.
	Shock absorber, Headset, Wheel	12 months	Man-made damage, self-modification, collision damage of parts and accessories are not warranted.
Electrics parts	Controller	12 months	Short circuit, burnout, performance failure due to poor manufacturing can be replaced. Water, disconnection, and man-made damage are not warranted.
	Charger, Main wiring harness	12 months	
	Display instrument, Throttle	12 months	
	Headlights, Taillights	12 months	
Motor parts	Motor, Hall, Bearing, Clutch	12 months	Phase loss, Hall element burnout, demagnetization, abnormal bearing noise can be replaced. Breakage, water ingress are not warranted.
Battery	Lithium battery	12 months	Replace the battery due to faults such as broken grids, no power storage, and less than 70% capacity. No warranty for water ingress or man-made damage

This Limited Product Warranty does not apply under the following circumstances:

1. Damage caused by operating the product outside the permitted or intended uses described by the manufacturer's instructions
2. Damage caused by incorrect operations, such as negligent, improper maintenance or incorrect use of the product.
3. Operation of the vehicle when it is overheating
4. Commercial use of the product, such as rental.
5. The products are damaged, misused, or tampered with from the original state it was delivered.
6. Unauthorised modifications to any part of the product, including but not restricted to:
 - a. Modification to controller
 - b. Modification to battery
 - c. Modification to motor
 - d. Modification to charger
 - e. Modification to throttle
 - f. Modification to power system
 - g. Modification to suspension
 - h. Modification to brakes
7. The battery is un-sealed.
8. Installing performance parts or components on the vehicle that change the original engineering.
9. Damage caused by servicing of the product (including upgrades and expansions) performed by anyone who is not authorised by Panmi/ Fiido to perform such services
10. Damage caused by nature or acts of God, for example, lightning strikes, cyclones, and the like.
11. Damage caused by natural wear and tear.

Disclaimer:

Unauthorised modifications from a third-party service provider can cause damage to the system of the dirt bike. This can result in fatal accidents. For your own safety, do not modify the dirt bike without authorisation from Fiido.

Fiido or its partners do not accept responsibility or liability for any loss, damage, cost or expense caused as a result of any unauthorised modification.

4.4 Repair record

Warranty card

User	Company			
	Name		Phone	
Address				
Purchase date			Color	
Model			Order No.	
Frame No.			Motor No.	

Repair record

Date	Maintenance	Remarks

Shenzhen Fiido Technology Development Co.,Ltd

Address: Shenzhen Fiido New Energy Technology Co.,Ltd
301, No.146, Hengping Road, Baoan Community, Yuanshan Street,
Longgang District, SHENZHEN GUANGDONG 51800, CHINA

Website: www.fiido.com

Contact us: support@fiido.com

If you have any questions or suggestions about this user manual,
please contact us via following mail address.



Scan for video instruction



Made in China