

C30R

User Manual

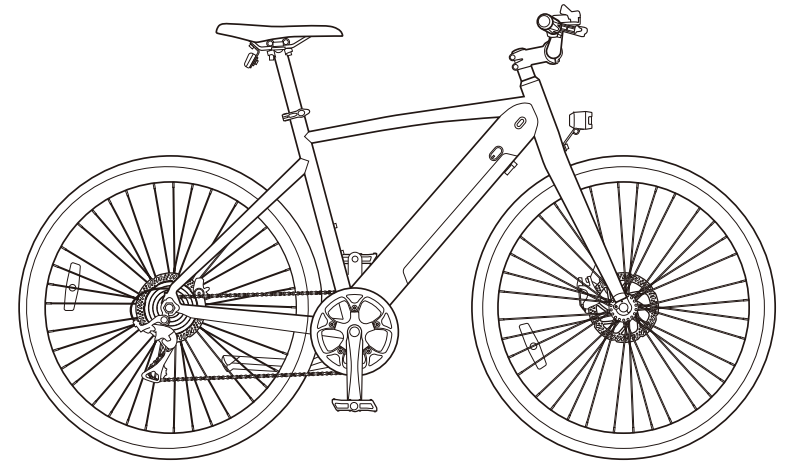

HIMO

DESIGN BY
HIMO



Description of User Manual and Manufacturer	2
Safekeeping of User Manual	2
Text Design Feature	2
Picture Design Feature.....	2
Applicable Document	3
Digital Copyright	3
Manufacturer's Contact Information	3
Safety Precautions	3
Intended Use	3
Unauthorized Refitting Prohibited	4
Rider's Body Type	4
Qualification of User and Rider	4
Personal Protective Equipment.....	4
Basic Safety Guidelines	4
Avoidance of Damage to Bicycle.....	5
Avoidance of Damage to Rider and Bicycle	5
Important Notes, Labels and Signs on Bicycle Safety	8
Warning and Information Signs	8
Bicycle and Components.....	9
Power	11
Brake System	11
Gearbox.....	12
Pedal	12

Unpacking and Open-box Inspection	12
Before Initial Riding	13
Dimension Inspection	13
Saddle Adjustment	13
Handlebar Adjustment	14
Battery Charging	14
Tire Pressure Inspection	14
Bicycle Control	15
Brake	15
Speed Change	15
Light ON/OFF	15
Bicycle Unfolding	15
Bicycle Folding	16
Display Specification-500S	16
Power-on or Power-off	17
Power Level Selection	17
Riding	17
During Riding	17
Safety Precautions about Riding	18
Power-assisted Riding	18
Unpowered Riding	19
Troubleshooting	19
Bicycle Transportation	20
Bicycle Maintenance	20

Battery Maintenance	20
Maintenance of Motor and Controller	20
Maintenance Plan	21
Service Record	22
Bicycle Recycling	23
Warranty Clause and Condition	23
Additional Information	23
Endurance Test	24
Test Method	24
Component Fixation	25
Seat Post Adjustment	25
Pedal Installation	26
Lubrication	26
Chain Tension	27
Gear Adjustment	27
Wheel Set Damage and Wear	28
Inflation Pressure	28
Description of Battery Maintenance and Charging.	28
Parts and Accessories List	29
Bicycle Card	29
Declaration of Conformity	30
C30R Screw Torque	31

Description of User Manual and Manufacturer

This User Manual is aimed at helping you use the electric folding bicycle safely. Unless otherwise specified functionally, the electric bicycle is hereinafter referred to as "bicycle". This User Manual is prepared according to IEC 82079-1 (preparation of planning, content and demonstration).

Safekeeping of User Manual

This User Manual is a part of the bicycle.

- Keep this User Manual properly together with the bicycle.
- Ensure the user can obtain this User Manual easily.
- Provide this User Manual while selling or distributing the bicycle.

Text Design Feature

All elements of this User Manual present fixed design features in order to distinguish from:

- Common text
- Action steps
- First-level list

Picture Design Feature

The pictures may contain numbers corresponding to components and descriptions are given to corresponding numbers below the pictures.

Applicable Document

The manufacturer's documents contain additional information and illustrations about bicycle components, which are also a part of this User Manual. Please keep them properly together with this User Manual and present them while selling or distributing the bicycle.

The risk of injury may be caused by violation of regulations of relevant documents.

Please read and comply with all other applicable documents before using the bicycle.

Applicable document includes the following documents:

Declaration of Conformity

Digital Copyright

Information contained in this User Manual shall be copyrighted. Without HIMO's written consent, this User Manual shall not be duplicated, printed, photographed, handled or distributed in any form.

The ownership shall be reserved by HIMO.

Manufacturer's Contact Information

SHANGHAI HIMO ELECTRICAL TECHNOLOGY CO., LTD.

Room K50, 1F, Building 6, No. 4299 Jindu Road, Minhang District, Shanghai City

Tel: +86(021)37655820-817

Email: luzhigang@himo-tech.com

Website: www.himo-tech.com

Safety Precautions

Intended Use

The bicycle shall be used by one person and can be used in auxiliary roads and public roads. The tires must always be in touch with the ground during riding. The bicycle shall be used for private purpose only and cannot be used for other purposes. Necessary safety equipment must be adopted in use, which shall be included in the assembly list.

The bicycle is not applicable to:

- Jump
- Stair riding
- Deepwater riding
- Sports event

The intended use also includes maintenance conducted as per the recommend time interval and reading and comprehension of this User Manual.

Unauthorized Refitting Prohibited

Refitting or refitting the bicycle improperly, especially improper operation and refitting of the motor and the controller, may result in serious damage beyond the warranty scope.

Be sure not to refit the controller or the motor by any means.

Rider's Body Type

At least 170cm

At most 190cm

Qualification of User and Rider

This User Manual is applicable to educated rider.

The rider should have the following knowledge and experience:

- Use the bicycle described in the distributor's User Manual effectively;
- Realize that improper use of the bicycle may cause an accident
- Able to use the bicycle as requested by this User Manual

Personal Protective Equipment

Severe injury or death may be caused during riding.

Please be sure to wear a certified helmet in riding, and adjust, use and maintain the helmet according to the manufacturer's manual.

- Please be sure to wear secure shoes with non-slip soles (such as special-shaped rubber soles).
- Please be sure to wear gloves.
- Please be sure to wear tights to avoid being caught by the bicycle or objects on the road.
- Please be sure to wear (transparent) dirtproof, dustproof and mothproof glasses.

Please be sure to wear sun glasses in sunny days.

Basic Safety Guidelines

Avoid severe injury or fatal injury caused by mechanical failure and improper use of the bicycle.

Severe injury and even death may be caused by mechanical failure or improper use during riding.

- Please be sure to carry out safety test before riding.
- Please get familiar with the brake, pedal and gear before riding.
- Please be sure to adjust the riding speed as appropriate.

Avoidance of Damage to Bicycle

Avoid electric shock or explosion caused by improper operation of battery and charger.

Electric shock or explosion may be caused by improper use of batteries and the charger and consequently severe injury or death may be caused.

- Only the batteries attached can be used.
- Be sure not to connect positive and negative poles of the batteries.
- Protect the batteries from direct sunlight.
- Please do not dismount or clean the batteries.
- Only the charger attached can be used to charge the batteries.
- The charger can be used indoors only.
- The charger plug is used to cut off the power. Please ensure the power socket is close to the charger for user-friendliness.
- The charger can be used for 230V grounding receptacle only. Please be sure to prevent the charger from water or any type of liquids.
- Keep metal contacts clean and clean them using soft dry cloth when necessary.
- Please do not charge batteries with damaged case and other obvious damages.
- Please prevent the batteries from falling off.
- Charge the batteries at a temperature of 10-30 °C.
- Ensure the charger is used by people without physical, sensory or mental disabilities only.

Avoidance of Damage to Rider and Bicycle

Avoid severe injury caused by contact between body parts and parts of the bicycle

Body parts or other objects may touch chain wheel, mobile chain, rotating pedal, crank and wheel of the bicycle during riding and consequently severe injury will be caused. Please be sure to avoid contact between body parts and the aforesaid parts.

- Please avoid contact between body parts and the aforesaid parts of the bicycle during riding.

Avoid severe injury or death in rainy days

Rainy and humid weather will the rider's and other road users' traction, braking force and visibility. In this case, your (and other road users') braking force will decrease exponentially, tread pattern has work efficiency inferior to dry pavement's, it is more complex to control speed and the rider will lose control of their bicycle, and consequently severe injury may be caused.

- Please be sure to ride a bicycle slowly in rainy and humid weather.
- Please be sure to brake carefully in rainy and humid weather.
- Turn off the motor or try to reduce the motor power and ride a bicycle carefully.

Avoid severe injury or death in the dusk or in the night

It is more dangerous to ride a bicycle in the dark at night than in the day and it is harder for the rider to identify other road users, and consequently severe injury or death may be caused.

- Do not ride a bicycle in the dark at night.
- Please be sure to ride a bicycle carefully.
- Please be sure to use light and reflector while riding a bicycle.
- Please be sure not to ride a bicycle in the dark and in rush hour.
- Please be sure to keep off obstacles on the road.
- If possible, please be sure to ride a bicycle on a familiar road.

Avoid severe injury caused by damaged parts

The motor, crank or bottom bracket may be damaged while riding a bicycle in the countryside or on the curb, and consequently severe injury may be caused.

- The rider is allowed to ride a bicycle on the approved road.
- In case of obstacles, please carry the bicycle.
- In case of damage, please inspect the bicycle at the distributor.

Avoid severe injury or death caused by damage or looseness of reflector and light

The reflector can capture and reflect light of street light, car headlight and other light sources so that the rider is easy to identify. The rider may be hard to identify if the reflector is damaged, bent or loose and consequently severe injury or death will be caused.

To avoid such accidents, you should:

- Request the distributor to replace the damaged, bent or loose reflector and the light.
- Inspect the reflector and the light regularly.

Avoid severe injury incurred while riding in the countryside or on the curb

If the speed is not controlled properly while riding in the countryside or in the sidewalk, the rider may fall down and consequently severe injury or death may be caused.

- Please be sure to adjust the riding speed as appropriate.
- Replace parts or add accessories appropriately in order to avoid severe injury or death.

Many components and accessories can improve comfortableness, performance and appearance of bicycle. The risk of adding components or accessories shall be borne by the user, since such components or accessories may not pass the test on compatibility, reliability or safety conducted by the manufacturer. Uncertified compatibility, reliability or safety and improper installation, use and maintenance of components or accessories of bicycle may result in severe injury or death.

- Please be sure to consult the distributor before installation, use and maintenance of components.
- Please be sure to read and comply with the instructions attached.

Avoid severe injury caused by improper maintenance, repair and cleaning

Improper maintenance, repair and cleaning may result in severe injury or death.

- Only activities set forth in the maintenance plan can be carried out.
- Only commercially available lubricant and detergent can be used.
- Only qualified distributor can carry out maintenance and repair.

Avoid severe injury or death caused by damaged parts

The bicycle and parts thereof will be worn (scratch, crack, wear and color change). The damaged parts may break down suddenly and consequently injury and death may be caused.

- Inspect wear of all parts (such as brake block and tire) regularly.
- Qualified distributor/specialist shall replace (if possible) or repair the damaged parts.

Avoid difficult breathing and suffocation

Brand new materials (such as oil paint) and high-temperature motor will produce volatile gases. Volatile gases will gather when the bicycle is stored indoors and consequently difficult breathing and suffocation may be caused.

- Please be sure to store the bicycle in a well-ventilated room.

Avoid burn injury

Parts of the bicycle (brake and tire) may heat up during riding and burn injury may be caused by touching these parts.

- Cool hot parts down before use or wear thermal protection device.

Avoid injury in the legs

The legs may be injured (relating to Q value) if the space between the pedals is too small. The rider may feel uncomfortable with the pedals.

- In this case, please inspect the bicycle at the distributor immediately.

Avoid vibration

The motor may work abnormally in case of improper assembly, wear and overload (e.g.: The motor is powered in the bumpy pavement and on the curb) or loose parts.

- The bicycle can be used on the approved road only.
- In case of crack or obvious damage, please consult the distributor/specialist about maintenance.
- Inspect whether the parts makes a correct response (e.g.: Shift the gear on a flat surface) and whether they function well before riding.
- The rider is allowed to ride a bicycle on the approved road only.

Avoid injury or uncomfortable experience

Men may have prostatic diseases after sitting on the saddle long and frequently.

- If necessary, install an ergonomic saddle suitable for women/men.
- When necessary, adopt preventive measures.

Avoid dehydration while riding

Riding is a strenuous physical activity.

- Please be sure to supply sufficient liquids. Please inspect the bicycle at the distributor.

Avoid cold injury

Cold injury may be easily caused while riding in cold weather

- Please be sure to wear suitable clothes in cold weather, including face shield, mask and gloves.

Avoid falling down due to sudden power

The bicycle may be out of control and overturned due to sudden power.

- Please be sure to test power function before initial riding.
- Please be sure to wear personal protective equipment.
- Please be sure to inspect default speed settings of the bicycle.
- Please be sure to thoroughly inspect braking force, speed and function before riding.

Environmental issues

The damaged parts (such as battery and electrical or electronic components) of the bicycle may produce toxic substances or gases and consequently environmental poisoning may be caused.

- Abandon waste batteries and electrical/electronic components of the bicycle according to laws and regulations.
- Please comply with the manufacturer's instructions during operation.



Avoid material damage

Property losses may be caused by improper use of battery.

- Ensure batteries are not fully discharged.
- The batteries can be stored in a dry place only.
- Please charge the batteries at least once every half year.

Important Notes, Labels and Signs on Bicycle Safety

Pay attention to the following warnings in this User Manual:

Warning	
	Warnings marked with "WARNING" are given against potential hazards and shall be avoided; otherwise, death or severe injury may be caused.
Warning	
	Warnings marked with "CAUTION" are given against slight injury or moderate injury.





Design features of material change:

Warning	
	Such warnings are given against material damage.

Warning and Information Signs

- Ensure all warning and information signs on the bicycle are legible.
- Replace the damaged or lost warning and information signs immediately.

The bicycle is provided with the following warning and information signs.

Sign	Description
	Common warning sign
	Hot surface
	Please do not use high pressure washer
	Please follow the instructions during operation
	Please be sure not to turn on the motor and the controller

Bicycle and Components

Description

The folding bicycle should be used in auxiliary roads and public roads and it can be folded using existing joints and hinges through several simple steps. Necessary materials are often included in the assembly list. Please ensure safety equipment is in place and at working condition before initial riding. Materials should be assembled by the user or the distributor.

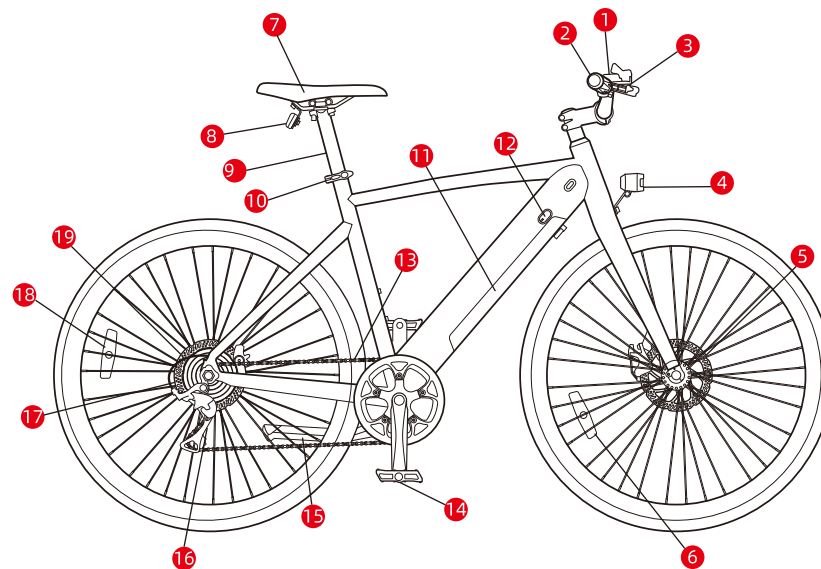

No.	Description	No.	Description
1	Instrument	16	Rear gearbox
2	Handlebar	17	Motor
3	Shift lever/Brake crank	18	Side reflector of rear wheel
4	Front light	19	Rear disc brake
5	Side reflector of front wheel		
6	Front disc brake		
7	Saddle		
8	Tail light		
9	Saddle tube		
10	Saddle tube quick release		
11	Battery		
12	Charging port		
13	Chain		
14	Pedal		
15	Ladder		

Bicycle

The packing list of the bicycle includes:

- Preassembled bicycle, including batteries
- Charger
- Two keys used to dismount the batteries (one for standby)

Power

Motor

The motor of the bicycle directly acts on the rear wheel and helps the user step on the pedal. The user can adjust the power of the motor using existing control system and select different grades of riding. The motor enables the maximum speed of 25km/h.

Battery pack

The power-assisted system should be furnished with batteries, which are installed in the frame.

The batteries can be removed using the key and charged. Only the charger attached can be used to charge the batteries.

Like most large batteries, lithium ion battery is a hazardous substance according to transportation regulations. The bicycle cannot be transported before the battery pack is installed. For air transportation, regulations on hazardous substances should prevail. (Please comply with local transportation regulations)

The packing box of battery pack must be marked with Danger during transportation.

Controller

The bicycle is furnished with a controller to adjust the power, which is controlled using the handlebar. The power of the controller is calculated according to preset speed, actual speed and pedal stress. The maximum speed is 25km/h. Power is not supplied above the maximum speed.

Brake System

The brake can control the bicycle to slow down or stop

Disc brake

The brake is installed on the front wheel and the rear wheel. The disc brake block acts on the disc to slow down. The brake disc will be worn and is controlled by the handlebar. The disc brake is a mechanical drive.

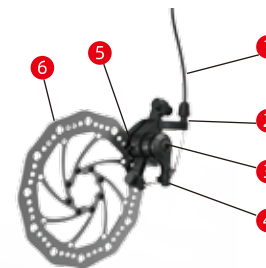

No.	Description	No.	Description
1	Brake cable	4	Locking screw of brake
2	Adjust screw of brake	5	Brake lining
3	Brake arm	6	Brake disc

Gearbox

The bicycle is furnished with gearbox.

Meaning of the following terms is as follows:

- Downshift means to shift to a lower gear so that it is easier to step on the pedal.
- Upshift means to shift to a higher gear so that it is hard to step on the pedal.

Gearbox

The gearbox consists of the following parts:

- The gear box or threaded chain wheel on the rear wheel
- Rear gearbox
- Tray/chain ring
- Drive/driven chain
- Shift level/gear lever

The gearbox shifts gears on the condition that the drive chain moves forward and is at least at tense state.

The user can select a suitable gear as appropriate.

e.g.: Shift to a higher gear to speed up in advance before climbing up a hill in order to save power.

Pedal

The pedal is installed at the end of the two cranks. Step on the pedal and the chain rotates to drive the chain wheel.

Unpacking and Open-box Inspection

Warning	
	The risk of suffocation may be caused by playing with aluminum foil. Children may be suffocated by wearing aluminum foil on the head. Prevent children from playing with aluminum foil. Keep the film out of children's reach.

Unpack the bicycle as follows:

- Open the box.
- Take the bicycle out of the box.
- Take the battery charger out of the box.
- Take two keys used to dismount the batteries out of the box.
- Inspect assembly list.
- Prevent children from playing with packing film in order to avoid suffocation.
- Dispose of packing materials according to local instructions and regulations.



Pedal

Inspect whether two pedals are correctly and fully tightened (to the last thread). Try to tighten the pedals and inspect them. Tighten the right pedal (on the side of the shifter) clockwise and the left pedal (on the side of the kickstand) anticlockwise.

Before Initial Riding

It is of great importance for safety, performance and comfortableness to adjust the bicycle properly. The user should have certain experience and adjust the bicycle using special tool according to physical and riding conditions; otherwise, the bicycle should be adjusted by specialist. If the user has experience, knowledge and tool, please accept the inspection conducted by specialist.

Dimension Inspection

Warning	
	The bicycle may fall down due to improper dimension and out of control and consequently severe injury may be caused. Ensure dimension of the bicycle is consistent with the user's height. Please do not ride a bicycle not consistent with your height.
Warning	
	The handlebar, the rider's response to steering and braking can be adversely affected;

Saddle Adjustment

It is of great importance for safety to adjust the saddle correctly. The user can adjust height of the saddle freely.

Please inspect whether height of the saddle is adjusted correctly as follows:

- Sit on the saddle
- Keep being seated
- Place a pedal downward
- Put feet on the pedals

If your legs do not extend completely when your feet are put on the pedals, height of the saddle is adjusted correctly.

Please adjust height of the saddle as follows:

- Release and open the quick release seat post clamp.

Then, move the saddle up and down and adjust the height.

- Adjust the saddle as needed.

Warning	
	The rider may fall down if the seat post is damaged and consequently severe injury may be caused. Ensure the minimum insertion mark (minimum insertion amount) on the seat post is in the seat tube and invisible.

- Close the quick release seat post clamp to reinstall the seat.
- Inspect whether height of the seat is adjusted correctly.
- If not, repeat adjusting steps.

Sitting on the saddle, the rider can tilt the elbow to operate the brake rod and the shift lever correctly.

Handlebar Adjustment

Adjust the handlebar of the bicycle
Please adjust the handlebar of the bicycle as follows:

- Open the front cover on the stem.
- Put on the handlebar and adjust the angle properly.
- Lock the front cover on the stem.

Battery Charging

Warning	
	The batteries may explode if a wrong charger is used and consequently severe injury or death may be caused. Only the charger attached can be used. Read and comply with the instructions in the charger specification.

The batteries should be charged at a temperature of 10-30 C .
Please charge the batteries as follows:

- Take out the batteries.
- Ensure no damage of battery case and other visible damages.
- Please charge the batteries on the surface of non-flammable objects, e.g.: ceramics.
- Comply with the instructions in the charger specification (if contained).
- Insert the charger plug into the socket on the batteries.
- Insert the charger plug into a 230V and 50Hz power socket and the light on the charger will be red. It takes 5-6 hours to charge the batteries. When the light turns green, it means that the batteries have been fully charged.
- Remove the plug from the socket.
- Remove the plug from the battery socket.
- Reinstall the batteries.

Tire Pressure Inspection

The user can identify the permissible inflation pressure range on the side wall of the tires.
Test inflation pressure of the tires.
Foot pump with pressure gage/pressure meter is recommended to inspect and correct tire pressure.

Bicycle Control

Brake

The brake is used not only to stop the bicycle but also to control the speed. The maximum braking force of the tires refers to the stress when the tires are "locked" (do not rotate) and slide. In case of tire slip, most braking force will be lost and the bicycle will be out of control. Please brake gently and stop the bicycle slowly, namely progressive braking skill, to prevent the tires from being locked.

- Push the brake to the handlebar to increase the braking force gradually.
- If the wheels are stuck, please release the brake so that the wheels can rotate and are not stuck.

Speed Change

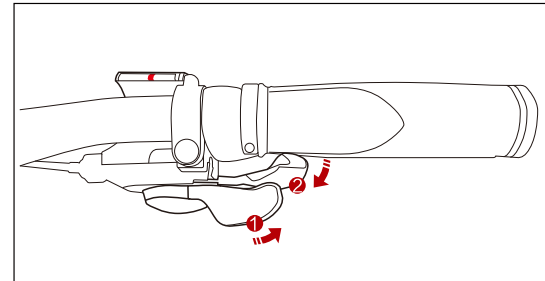

- ①: Toggle it to downshift, making it slower and more labor-saving
- ②: Toggle it to uplift, making it faster and more laborious

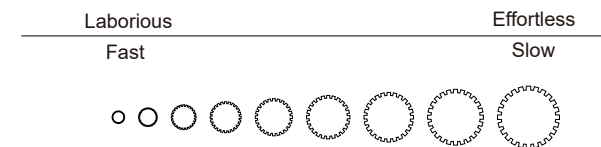

- To speed up, start with a lower gear at the beginning, and change to a higher gear as the speed increases.
- The speed will decrease when going uphill. Lower the gear to maintain a certain pedaling force
- The speed will increase when it is downwind, Increase the gear to maintain a certain pedaling force

Light ON/OFF

The light is powered on by built-in batteries. Please ensure the batteries are fully charged while riding at night.

Turn on or turn off the light as follows:

- Turn on the switch of the front light.
- Turn on the light even in the day so that it is easier for other road users to identify the bicycle.

Display Specification-C30R

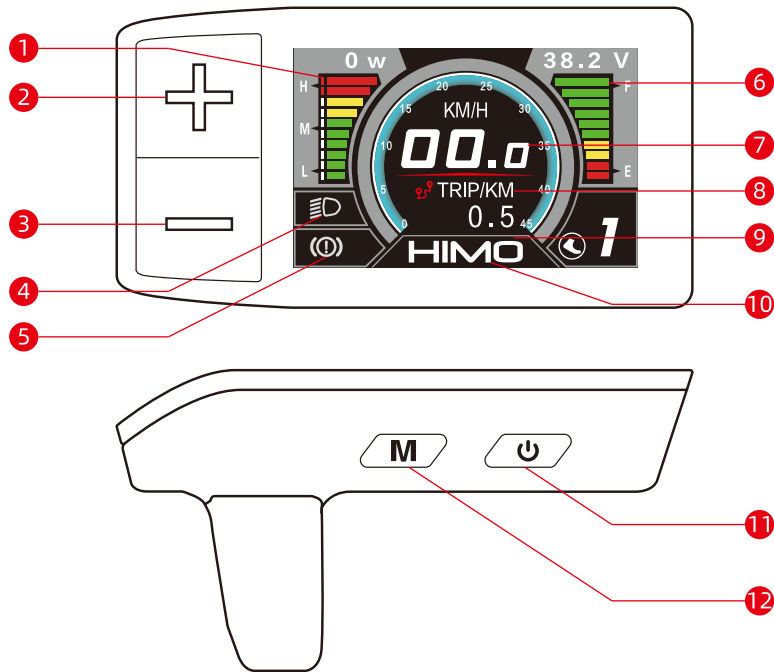

No.	Part description	No.	Part description
1	Power indicator	8	Mode and mileage display
2	Up key	9	Gear display
3	Down Key	10	Logo and error code display area
4	Headlight indicator	11	Power key
5	Brake indicator		Mode key
6	Battery level		
7	Speed display		

Power-on or Power-off

Please turn on the display as follows:

- Press and hold “⏻” for about 3s.

Please turn off the display as follows:

- Press and hold “⏻” again for about 3s.

Power Level Selection

According to the selected power level, power exercise can help you step on the pedal.

Five power levels are optional:

- 1 ■ 2 ■ 3 ■ 4 ■ 5

Please select the power level as follows:

- Turn on the controller
- Press “+” again to select a higher power level.
- Press “-” again to select a lower power level.

Light ON and OFF

- Press and hold “+” for 3s to turn on the light.
- Press and hold “+” for 3s to turn off the light.

Riding

During Riding

Please be sure to wear a helmet consistent with the latest certification standard during riding. For adjustment, use and maintenance of helmet, please refer to the manufacturer's specification. Most severe injuries are caused to the head during riding, which can be prevented through wearing a helmet.

According to regulations on release of road traffic permit, the following equipment is needed for riding a bicycle safely on public roads:

- A bell
- Two independent brake systems
- White front light
- Front white reflector
- red rear light
- rear red reflector
- Two yellow reflectors are installed on the spoke of every wheel with a deviation angle of 180° or a white reflector is installed on the tire.
- A yellow reflector is installed on the front and rear pedals.

The front light should be approved according to regulations of the host country/area.

Before riding, make sure that:

- The batteries have been fully charged
- The brake, chain guard and fender work normally
- The handlebar is connected securely and adjusted properly
- The saddle is connected securely and adjusted properly
- The pedals are connected securely
- The wheels are connected securely
- The tires are connected securely
- Tire pressure is correct
- The lights are normal and are adjusted properly
- The circuits are normal and are adjusted properly
- The quick release screw, nut and operating lever are secure

Safety Precautions about Riding

- Fully comply with regional traffic laws and regulations on bicycle. Comply with regulations on bicycle registration and riding on sidewalk and laws on the use of bikeway. The user is obliged to get familiar with and comply with laws and regulations.
- Respect the rights of motorway users, pedestrians and other riders on the same road/bikeway.
- Keep the lights on.
- Ride a bicycle foreseeingly. Please be sure to suppose that others cannot see you.
- Observe before crossing the road.

The user also should make the following preparations:

- The car ahead brakes or reverses and the car behind approaches
- The door of a parked vehicle is opened
- Pedestrians in the street
- Children or pets playing on the roadside
- Pit, trench, railway and expansion joint
- Construction of road or sidewalk, rumbles or other obstacles which may force you to use the opposite lane
- An accident is caused by evading or being caught by the bicycle or losing control
- Ride in the designated bikeway or ride as close to the roadside as possible according to regional regulations or along the traffic direction
- Park in front of parking sign and traffic light. Observe around while braking at the intersection.
- Remember that a rider is always the weakest road user
- Please use common gestures while turning a corner or parking
- Be sure not to wear a headset while riding since it can shield the whistle easily
- Traffic noise and whistle may distract the rider and make the rider out of control
- Be sure not to carry anyone while riding. Eligible helmet and correctly installed child seat or baby cart must be used to carry infants. For weight restrictions, please follow the manufacturer's suggestions for child seat or baby cart
- Be sure not to carry any objects which will obstruct the rider's view, will affect the rider's control over the bicycle or will be stuck by moving parts of the bicycle
- Please avoid being dragged by other vehicles while riding
- Please do not perform special effects, ride on a single wheel or jump; otherwise, the bicycle may be damaged
- Be sure not to cross the road, ride around and behave in the ways that other road users cannot predict
- Ride a bicycle foreseeingly and pay attention to order of importance and emergency
- Be sure not to ride after drinking wine or taking drugs
- Try not to ride in severe weather, at poor visibility, in the dusk, in the night or under fatigue; otherwise, accident risk will increase.

Power-assisted Riding

If you have never ride a power-assisted bicycle, please get familiar with it in an open space. The power device will be activated only after it is powered on and the rider is stepping on the pedal. It may be a little uncomfortable in the beginning, but the rider will get used to it soon. The rider should set on the saddle before stepping on the pedal.

Do daily exercise from the minimum level of riding, e.g.:

- Starting
- Accelerating
- Braking
- Turning a corner

Stop stepping on the pedal and the power-assisted system will still provide power within a short time.

The power-assisted endurance mileage is determined by the following factors:

- Total weight of bicycle, rider and luggage
- Speed control
- Tire pressure

- Battery level
- Road condition
- Weather
- Following the wind or against the wind
- Personal energy

To reach the maximum mileage, please follow the steps below:

- Ensure the batteries have been fully charged.
- Ensure tire pressure is adjusted properly.
- Do not use or select a low power level on the flat ground or a downward slope.
- Select a suitable gear according to riding condition.
- Please turn off the power-assisted system while riding for a short distance in order to avoid unnecessary start and stop.

Unpowered Riding

You can also use an unpowered bicycle. Turn off the power-assisted system and the bicycle is an unpowered bicycle.

e.g.: When the batteries are exhausted.

Troubleshooting

Problem	Possible cause	Solution
The display does not work	The batteries have been exhausted or the bicycle is not connected to the batteries	Ensure the batteries have been charged and installed correctly. Ensure the batteries have been locked in order to avoid disconnection between the batteries and the bicycle during riding
The green light of the charger lights up, but the batteries cannot be charged	The batteries are not connected to the charger correctly	Please be sure to connect the charger to the batteries and then insert it into the socket in the wall
Please be sure to connect the charger to the batteries and then insert it into the socket in the wall	It may be caused by adverse wind, mountain road, rider's weight, speed adjustment and tire pressure	

Bicycle Transportation

Warning	
	<p>The folding bicycle may fall off or slip off during transportation and consequently severe injury may be caused. The bicycle should be protected from turning over, slipping off and falling off when transported by vehicles or public transportation facilities.</p> <p>Please transport the bicycle using certified luggage carrier. If there is no luggage carrier, the bicycle must be placed in the trunk (it cannot be placed on the gearbox).</p>

Bicycle Maintenance and Repair

Battery Maintenance

The design charging cycle of battery is about 500 times. After the batteries are charged for 500 times, the battery level will no longer reach 100% but about 60%. A charging cycle refers to that the battery level increases from 0% to 100%. If the battery level increases from 99% to 100%, it is not a complete charging cycle but only 1% of a complete charging cycle. Generally, a charging cycle can last for more than two years.

When the battery level is 75%, the batteries can be stored for about three months. When the battery level is 50%, the batteries can be stored for about two months.

In order not to reduce the service life of battery, please follow the steps below:

- Charge the batteries when the battery level is 30%-50% after riding.
- Ensure the batteries are not fully discharged.

It takes 5-6 hours (from 1%-100%) to charge the batteries after fully discharged.

To store the batteries for more than two months, please follow the steps below:

- Take out the batteries.
- Ensure no damage of battery case and other visible damages.
- Charge the batteries before stored for a long time.
- Store the batteries in a safe and dry place.
- Store the batteries at a temperature of 5-20 °C.
- Prevent great temperature variation of battery.
- Please do not store the batteries under sunlight or high temperature.

e.g.: When the batteries are stored in a warehouse.

- Please charge the batteries at least every two months.

Maintenance of Motor and Controller

Warning	
	<p>Moisture, pollution or mechanical damage may cause short circuit and consequently a fire or battery explosion may be caused.</p> <p>Clean the motor and the controller using wet sponge from outside. If the motor and the controller are immersed in water accidentally, please pull out the plug immediately and disconnect the motor and the battery. Consult the manufacturer before powering on the motor again.</p>

Clean the motor and the control system using wet sponge from outside.

Maintenance Plan

Interval	Component	Operation
After riding for a long time or for at least 150km	Bicycle chain	<p>Clean the bicycle and lubricate the chain gently. Remove excess oil using cloth.</p> <p>Dispose of duster cloth in an environmental way.</p> <p>Use commercially available detergent and lubricant.</p> <p>Comply with safety instructions for similar products and environmental regulations on relevant substances.</p>
After riding for a long time or for 10-20 hours (high-intensity)	Finished bicycle	<p>Inspect whether the bicycle is damaged.</p> <p>Dismount the bicycle. When necessary, it should be repaired by a qualified distributor.</p>
After riding for 25km (high-intensity) to 50km (highway)	Finished bicycle	<p>Inspect whether the bicycle is damaged.</p> <p>Dismount the bicycle. When necessary, it should be repaired by a qualified distributor.</p>
When necessary	Frame, rim and pedal	<p>Remove dirt using suitable brush.</p> <p>Clean components using wet cloth and neutral soap solution.</p>

Service Record

In order to maintain your warranty right, the bicycle should be not only maintained regularly but also inspected carefully once or twice every year.

Bicycle Recycling

Please recycle the abandoned bicycle according to the following procedure:

- Abandon bicycle and parts thereof such as batteries and electrical components in a recycle bin according to local laws and regulations.
- Recycle the bicycle according to the manufacturer's instructions for batteries and electrical components.



Warranty Clause and Condition

The bicycle is manufactured by SHANGHAI HIMO ELECTRICAL TECHNOLOGY CO., LTD. at Room K50, 1F, Building 6, No. 4299 Jindu Road, Minhang District, Shanghai City.

SHANGHAI HIMO ELECTRICAL TECHNOLOGY CO., LTD. offers 1-year legal guarantee for frame and front fork as of the purchase date and warranty service for any manufacturing problems or material defects, including breakage or tear incurred during normal riding (except improper use).

All vulnerable parts should be excluded from the warranty scope, e.g.: chain, pedal, synchronous belt, tire, rim, hose, bearing, gearbox hanger, brake block, chain wheel, pinion, underframe, outer tube of shifter and brake cable, oil paint and paster.

All damages arising from non-compliance of assembly instructions or improper use (jump, special effect, single-wheel riding and alpine drop). The bicycle can be used for private purpose only. Damages arising from rent, lease or participation in competition should be excluded from the warranty scope. Unauthorized maintenance or refitting should be excluded from the warranty scope. Regular maintenance not accordance with this User Manual or careful inspection conducted at least once or twice per year should be excluded from the warranty scope. To apply for warranty service, please keep the original proof of purchase and the service manual. Contents in the warranty scope should be validated as of the purchase date.

Additional Information

- Manufacturer's or authorized representative's contact information and address;
 - Compliance with EN 15194 EPAC standard;
 - Applicable marks (CE) according to regulations;
 - Year of manufacture, namely completion date of manufacture (it cannot be a code);
 - Maximum speed 25km/h;
 - Maximum continuous rated power 0.25KW;
 - Maximum permissible total weight (e.g.: Marked near the seat post or the handlebar);
 - Name of series or type;
 - Single serial No. (if any);
 - Quality (if the mass of the electric power-assisted bicycle exceeds 25kg);
 - Under the most common configuration, mass of the electric power-assisted bicycle.
- The frame should:
- Be in a conspicuous position, e.g.: Near the pedal crank, seat post or handlebar, and be marked with continuous number obviously and permanently;

- Be marked with name of manufacturer or manufacturer's representative of the power-assisted bicycle and serial number of this document, namely EN 15194.. Endurance test method should be specified in "Endurance test". If appropriate, the power-assisted bicycle is furnished with trailer coupling device and the following data should be provided:
- Total weight of trailer;
- Vertical load of coupling system. Attention: Some countries/areas have legal requirements for bicycle mark. There are no special requirements for components, but the following key safety components should be provided with legible and permanent traceable mark, e.g.: manufacturer name and part number;
- Front fork;
- Handlebar and handlebar rod;
- Seat post;
- Brake level, brake block and/or brake block frame;
- Outer tube of brake cable;
- Hydraulic brake oil pipe;
- Disc brake calipers, brake disc and brake block;
- Chain;
- Pedal and crank;
- Underframe spindle;
- Rim.

Endurance Test

Requirement

- When endurance is tested using the method described in "Test method", mark should be legible and hard to remove and should not be curly

Test Method

Wipe for 15s using a piece of cloth with water and then wipe for 15s using a piece of cloth with benzoline.

- Warning 1-Like all mechanical parts, the power-assisted bicycle will be affected by wear and high stress. Different materials and parts may respond to wear or stress fatigue differently. If the design life of a part expires, the part may break down suddenly and consequently the rider may be injured. Any form of crack, scratch or change in color of the highly stressed area indicates that the service life of the part expires and the component should be replaced.
- Warning 2-The user may not see impact damage of parts made from composite materials and the manufacturer should explain the impact damage and its consequences. The parts made from composite materials should be returned to their manufacturer for inspection or destruction and replacement.
- The weighted A noise at ears of the rider should be less than 70dB (A).
- The bicycle must not be tampered deliberately or refitted without authorization.
- The manufacturer/seller does not assume any responsibility for damage arising from the user's tampering and the user should ask for help from professionals.
- The child seat cannot be installed below the bicycle.
- Be sure not to clean the bicycle using high pressure cleaner.
- For minimum height and dimension of the saddle, please refer to the minimum insertion mark on the seat post.
- The total permissible load of the bicycle (including rider) is 75kg.
- The bare weight of the bicycle is about 22kg.
- The bicycle cannot be designed with a trailer.

Component Fixation

Please be sure to inspect fixation of bicycle, brake, tire and screw/nut before riding. Ensure all brake cables are connected well and the torque should be 8-10N.m.

After the wheel is loosened, please adjust it according to the recommended torque.

The seat height can be adjusted using the seat post clamp. Pull the seat post clamp open and insert the seat post to at least the minimum insert line marked on the seat post. Tighten the nut through twisting the quick release rod of the seat post clamp and push the quick release rod to the OFF position.

The seat angle can be adjusted using the nut at the joint between the seat and the seat rail. The nut should be tightened so that the seat will not move forward or backward when the rider is seated.

Seat Post Adjustment

The seat post should be adjusted as follows:

- Pull the quick release handle outward and lower the stand pipe to the bottom

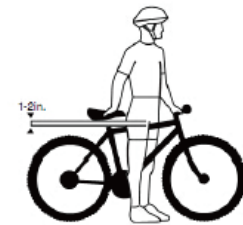
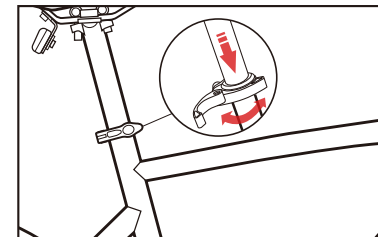

The seat height can be adjusted using the seat post clamp. Pull the seat post clamp open and insert the seat post to at least the minimum insert line marked on the seat post. Tighten the nut through twisting the quick release rod of the seat post clamp and push the quick release rod to the OFF position.

The seat angle can be adjusted using the nut at the joint between the seat and the seat rail. The nut should be tightened so that the seat will not move forward or backward when the rider is seated.

Size of frame		
Rider's leg length	Recommended size of road/touring bicycle frame	Recommended size of mountain/hybrid bicycle frame
61-69cm/24-27 in.	-	37cm/14.5 in.
66-76cm/26-30 in.	-	43cm/ 17 in.
71-79cm/38-31 in.	50cm/19.5 in.	45cm/18 in.
76-84cm/30-33 in.	55cm/21.5 in.	50cm/19.5 in.
79-86cm/31-34 in.	57cm/22.5 in.	52cm/ 20.5 in.
81-89cm/32-35 in.	60cm/23.5 in.	53-56cm/21-33 in.
86-94cm/34-37 in.	63cm/25 in.	58-60cm/23-23.5 in.

Pedal Installation

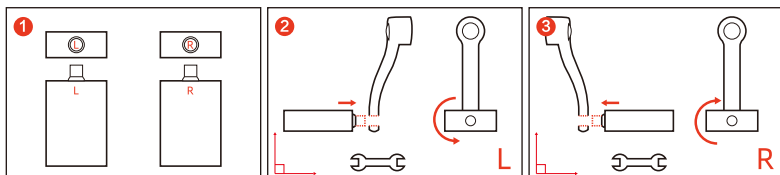

1. Pay attention to the letters to distinguish from the left and right pedals, L represents the left pedal and R the right pedal.

2. While installing the left pedal, the end face of pedal bolts should be vertical to the mounting hole of the crank. Rotate and tighten **anticlockwise** (using 15# open spanner)

3. While installing the right pedal, the end face of pedal bolts should be vertical to the mounting hole of the crank. Rotate and tighten **clockwise** (using 15# open spanner)

Lubrication

Use light machine oil (20W)

Part	Lubrication plan	Recommend lubrication method
Pedal	Every 6 months	Apply 4 drops of machine oil to the joint between the pedal and the pedal spindle
Chain	Every 6 months	Apply 1 drop of machine oil to every roller of the chain
Underframe	Every 6 months	Contact professionals
Motor	Every 6 months	Contact professionals

Please remove dust before lubrication and remove lubricant after lubrication.

Chain Tension

Please thoroughly read the chain tension adjustment manual attached for a detailed understanding of chain tension adjustment.

- Ensure to lubricate and clean the chain so that it functions well.
- Chain tension should be adjusted correctly by qualified technical personnel.
- Maintenance should be conducted especially in a humid or dusty environment.
- Chain tension should be about 15mm.
- While adjusting the chain, loosen the nut of the rear spindle, adjust the fastening screw of the chain and tighten the screw of the rear spindle.

Gear Adjustment



Know the gear level:

- The gear has the same working principle as ordinary bicycle, which is unrelated to the motor.
- The DIP shifter is installed on the right of the handlebar. Pull the “+”/ “-” handle to raise/lower the gear.
- The lower the gear level is the more energy will be saved. Vice versa.
- The gear level has been preset upon delivery and needs not be adjusted.
- After used for a period of time (3 months), the shift cable will be extended and may need to be adjusted.
- A local bicycle store or the exclusive shop of the electric bicycle can provide this service.

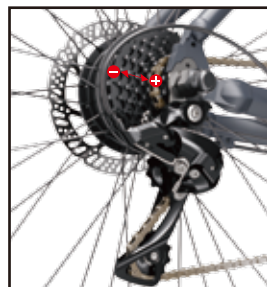

Wheel Set Damage and Wear

- Ensure the inflating volume of the tires is limited to the recommended value indicated on the side wall of the tires.
- Ensure the tires have patterns and are free from bulge or excess wear.
- Ensure the rims run normally and do not waggle or bend obviously.
- Ensure all wheel spokes are secure and not broken.
- Inspect whether the nut of the spindle is tightened. If the bicycle has a quick release spindle, please ensure the locking lever is fastened and at OFF position.

Inflation Pressure

While inflating the tires, please be sure to check the tire pressure.

Description of Battery Maintenance and Charging

- Please charge the batteries for 6-10 hours when the battery level decreases to 30%-50% in order to extend the service life. If stored at a low battery level, the batteries will be exhausted and cannot be reused. Please charge the battery pack fully after long-distance riding. Please do not charge the batteries for a long time (namely "more than 10 hours") in summer in order to avoid damage.
- The batteries should be charged monthly during storage.
- The charging temperature should be 0-45 C.
- The battery pack may not be fully charged if the temperature is too high or too low.
- The temperature may rise slightly when the batteries are charged, but it should be limited to 50 C. If the indicator light of the charger remains unchanged or the batteries are very hot (the temperature is above 50 C) after the batteries are fully charged, please consult the seller about maintenance immediately.
- After the batteries are removed from the bicycle, try to reduce vibration and disturbance in order to avoid damage. Keep the charger far away from water.
- Every battery pack is designed with a charger. Please do not charge the battery pack using other types of charger in order to avoid burn-out of batteries and danger thus incurred.
- The batteries should be stored at a temperature of 0-45 C in a clean, cool, dry and well-ventilated place. The batteries should be protected from sunlight, fire, flood and corrosive substance during transportation and storage.
- Please keep the button at the head of the battery holder at "ON" during charging.
- Please ensure no short circuit of the socket in the wall in order to avoid burn-out of batteries and danger thus incurred.
- Please do not pull out the power key while riding at high speed.

Parts and Accessories List

All specifications will be attached to the bicycle.

Pedal

- Please pull the pedal outward and fold it downward before storage or transportation. (The movement direction of the pedal is shown below)



Seat post

- Attention: Please do not raise the seat post above the minimum insertion line indicated on the seat post.



Bicycle Card

Full name	
Address	
Post code	
Telephone/mobile number	
Fax	
Purchase date	
Bicycle name	
Frame number	
Wheel size	
Color	
Special function/accessories	

Declaration of Conformity

C30R Screw Torque

Unit: N.m

System	Location	Specification	Torque value
Drive system	Right spindle axle-bowl	BC1.37 24T	35-45
	Left spindle axle-bowl	BC1.37 24T	35-45
	Fixed screw for chainwheel and crank	M8	20-25
	Freewheel locking		30-40
	Central spindle of pedal	9/16"、1/2"	20-25
Steering system	Fixing of the handlebar and stem	M5	6-8
	Upper cover of the stem	M5	1.5-4
	Fixed screw for stem and front fork	M6	8-10
Wheel	Quick release of Front hub nut	Pull-out force	>70
	Rear hub nut	M12	30-35
Transmission system	Rear derailleur	M10	8-12
	Front derailleur	M5	7-9
	Derailleur inner cable	M5	4-7
	Locking screw of transmission handle	M6	8-10
	Frame lug	M3	1-3
Saddle system	Seat cushion and seat cushion rod	M6	8-10
	Quick release of saddle pipe	Pull-out force	>10
Brake system	Brake handle	M5	6-8
	Brake disc	M5	6-8
	Fixing of disc brake and front fork	M6	10-12
	Fixing of disc brake and frame	M5	7-9
	Brake inner cable	M5	4-7
Accessories	Fixing of the kickstand and frame	M10	18-23
	Headlamp screw	M6	8-10
	Bell		1-3
	Valve nut		1-2