



The manufacturer reserves the right to make changes to the product, release firmware updates, and update this manual at any time. Visit www.segway.com or check the Segway-Ninebot App to download the latest user materials. You must install the App, activate your KickScooter, and obtain the latest updates and safety instructions.

Ninebot KickScooter MAX

User Manual



Contents

1 Riding Safety	02
2 Packing List	04
3 Diagram	05
4 Assembling	07
5 Charging	08
6 Activation	09
7 How to Ride	10
8 Warnings	12
9 Folding and Carrying	17
10 Maintenance	19
11 Specifications	21
12 Trademark and Legal Statement	22
13 Limited Warranty	25

Original Instructions

Thanks for choosing the Ninebot KickScooter MAX!

Thanks for choosing the Ninebot KickScooter MAX (hereinafter referred to as KickScooter)!
Your KickScooter is a recreational product with a mobile app, allowing you to connect with other riders.
Enjoy your ride and connect with riders worldwide!



The pictures shown are for illustration purposes only. Actual product may vary.

Riding Safety

1. The KickScooter is a recreational product. Before mastering riding skills, you need to practice. Neither Ninebot Inc. (means Ninebot (Beijing) Tech Co., Ltd. and its subsidiaries and affiliates) , hereinafter referred to as, collectively, Ninebot Inc. nor Segway Inc. is responsible for any injuries or damage caused by a rider's inexperience or failure to follow the instructions in this document.
2. Please understand that you can reduce the risk by following all the instructions and warnings in this manual, but you cannot eliminate all the risks. Remember that whenever you ride the KickScooter you risk injury from loss of control, collisions, and falls. When entering into public spaces always comply with the local laws and regulations. As with other vehicles, faster speeds require longer braking distance. Sudden braking on low traction surfaces could lead to wheel slip, or falls. Be cautious and always keep a safe distance between you and other people or vehicles when riding. Be alert and slow down when entering unfamiliar areas.
3. Always wear a helmet when riding. Use an approved bicycle or skateboard helmet that fits properly with the chin strap in place, and protects the back of your head.
4. Do not attempt your first ride in any area where you might encounter children, pedestrians, pets, vehicles, bicycles, or other obstacles and potential hazards.
5. Respect pedestrians by always yielding the right of way. Pass on the left whenever possible. When approaching a pedestrian from the front, stay to the right and slow down. Avoid startling pedestrians. When approaching from behind, announce yourself and slow down to walking speed when passing. Please obey local traffic laws and regulations if the situation is different.
6. In places without laws comply with the safety guidelines outlined in this manual. Neither Ninebot Inc. nor Segway Inc. is responsible for any property damage, personal injury/death, accidents, or legal disputes caused by violations of the safety instructions.
7. Do not allow anyone to ride your KickScooter on his/her own unless they have carefully read this manual. The safety of new riders is your responsibility. Assist new riders until they are comfortable with the basic operation of the KickScooter. Make sure each new rider wears a helmet and other protective gear.
8. Before each ride check for loose fasteners and damaged components. If the KickScooter makes abnormal sounds or signals an alarm, immediately stop riding. Call your dealer/distributor for service.
9. Be alert! Scan both far ahead and in front of your KickScooter — your eyes are your best tool for safely avoiding obstacles and low traction surfaces (including, but not limited to, wet ground, loose sand, loose gravel, and ice).
10. To reduce the risk of injury, you must read and follow all "CAUTION" , "WARNING" and "" notices in this document. Do not ride at an unsafe speed. Under no circumstance should you ride on roads with motor vehicles. The manufacturer recommends riders be 18+ years old. Always follow these safety instructions:
 - A. People who should not ride the KickScooter include:
 - i. Anyone under the influence of alcohol or drugs.
 - ii. Anyone who suffers from a disease that puts them at risk if they engage in strenuous physical activity.
 - iii. Anyone who has problems with balance or with motor skills that would interfere with their ability to maintain balance.
 - iv. Anyone whose weight is outside the stated limits (see Specifications).
 - v. Pregnant women.
 - B. Comply with local laws and regulations when riding this product. Do not ride where prohibited by local laws.
 - C. To ride safely, you must be able to see what is in front of you and you must be visible to others.
 - D. Do not ride in the snow, in the rain, or on roads which are wet, muddy, icy, or that are slippery for any reason. Do not ride over obstacles (sand, loose gravel, or sticks). Doing so could result in a loss of balance or traction and could cause a fall.
11. Do not attempt to charge your KickScooter if, the charger or the power outlet, is wet. Please read the user materials before charging the battery.
12. As with any electronic device, use a surge protector when charging to help protect your KickScooter from damage due to power surges and voltage spikes. Only use the original supplied charger. Do not use a charger from any other product models.
13. Use only Ninebot or Segway approved parts and accessories. Do not modify your KickScooter. Modifications to your KickScooter could interfere with the operation of the KickScooter, could result in serious injury and/or damage, and could void the Limited Warranty.
14. Children should not play with the KickScooter or parts of it nor should cleaning or maintenance be done by children. The use of the machine results in the transmission of vibrations throughout the driver's body.
15. Always place the KickScooter on its kickstand on a flat and stable surface. The KickScooter must be placed with the kickstand against the slope to prevent it from tipping over. Never place the KickScooter with the front facing down the slope, which may cause your vehicle to tip over. Once the KickScooter is stably parked, check its stability to avoid any risk of falling (by slip, wind or slight jolt). Do not park the KickScooter in a busy area, but rather along a wall.
16. For a better riding experience, it is recommended to conduct regular maintenance of the KickScooter.
17. Do not touch the brake system, it could cause injuries.

📄 Packing List

Assembled KickScooter



User Manual x1

Accessories



Hex Wrench



M5 Screw × 6



Power Cord



Valve Stem Extension

📐 Diagram

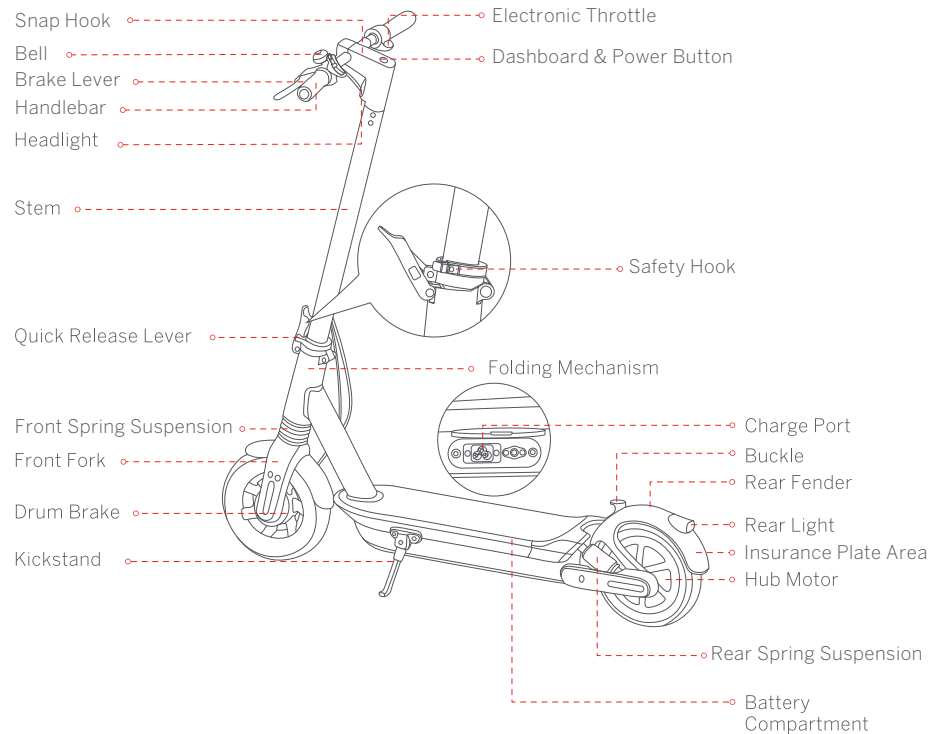

Dashboard & Power Button

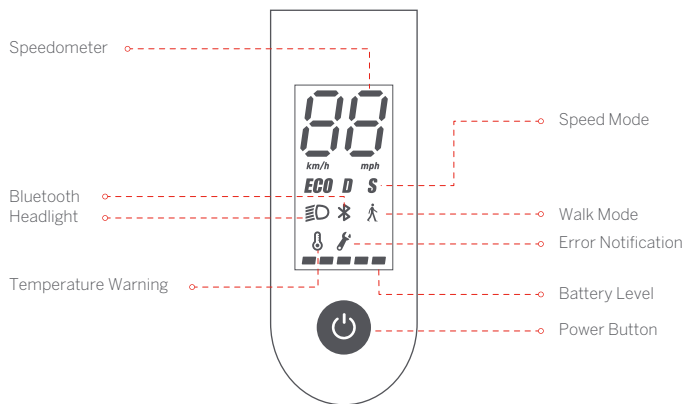

Power Button: Press the button to turn on; press and hold the button for 3 seconds to turn off. When the KickScooter is on, press the button to turn on/off the headlight and the rear light, and press twice to switch between the speed modes.

Speedometer: It displays the current speed of the scooter, as well as error codes.

Walk Mode: Max. speed is 5 km/h (3.1 mph).

The headlight and rear light are always on and can't be turned off.

* How to enable it in the Segway-Ninebot app: Tap the sidebar menu > **Settings** > **Walk Mode**.

Speed Mode: There are three modes. The top speed is as follows:

Mode	Model	G65E
ECO (Energy-saving mode)		15 km/h
D (Standard mode)		20 km/h
S (Sport mode)		25 km/h

Error Notification: It indicates that the scooter has detected an error.

Temperature Warning: It indicates that the battery temperature has reached 55°C (131°F) or is below 0°C (32°F).

* At this point, the vehicle cannot accelerate and may not be charged. Do not use until the temperature has reverted to the normal range.

Bluetooth: It indicates that the scooter has been successfully connected to the mobile device.

Battery Level: The total battery level equals 5 bars.

* The battery power is very low when the first battery bar is red. Please charge your KickScooter immediately.

Assembly

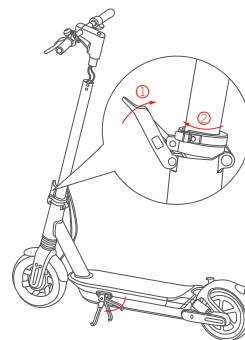

1 Unfold the stem. Close the quick-release lever, and lock with the safety hook.

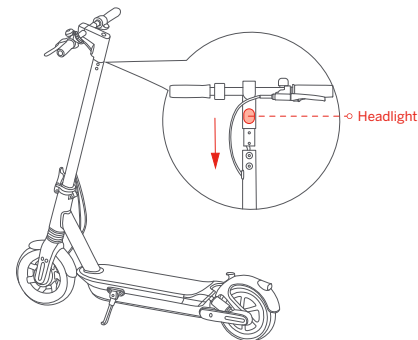

2 Slide the handlebar onto the stem with the headlight facing forward.

* Make sure the wires inside the handle and the stem are connected.

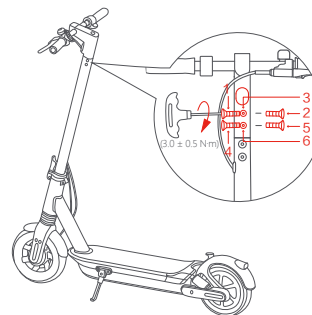

3 Install the six screws in order (two on each side) with the included hex wrench.

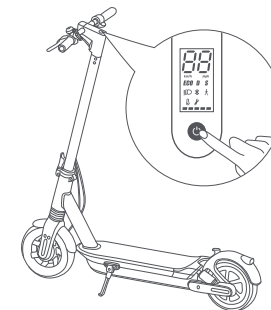

4 Power on the KickScooter.

5 Charging

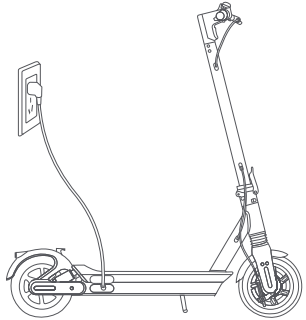

Charge the KickScooter for three seconds to activate the battery before the first use. Otherwise, your KickScooter cannot be powered on.

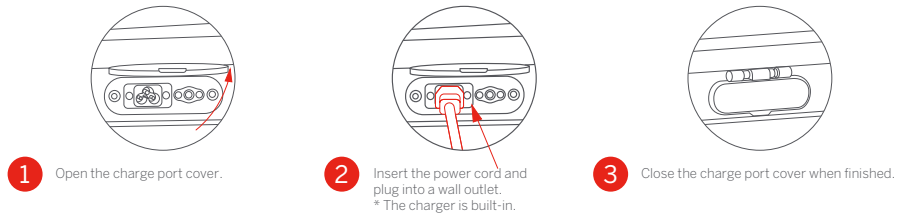

When charging, the speedometer icon indicates the current battery level when the KickScooter is powered on.



When the scooter is not powered on for seven consecutive days and its battery level is under 30%, the battery will enter into sleep mode. If this happens, your scooter cannot be powered on. Please charge it for three seconds to activate the battery.

6 Activation



1 An inactivated KickScooter will keep beeping when turned on, and its speed is limited to 9.3 mph (15 km/h).

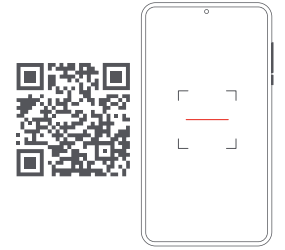

2 Scan the QR code to download the Segway-Ninebot App and register/log in.

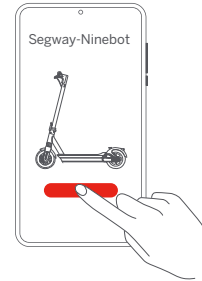

3 Click "Search vehicle" and pair to connect to your KickScooter.

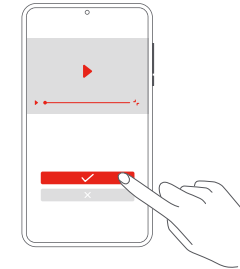

4 Follow the instructions to watch the Riding Safety.

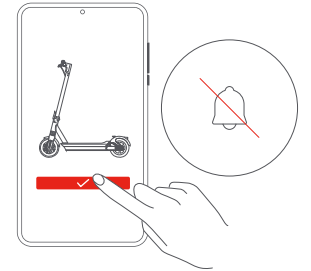

5 Click to activate the KickScooter.

How to Ride

Note: For your safety, the motor will not engage until the KickScooter reaches 1.9 mph (3 km/h).

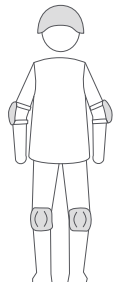

Warning: Always wear a helmet, elbow pads and knee pads when riding.

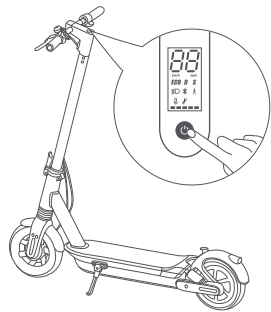

1

Power on the KickScooter.



2

Stand on the footboard with one foot and push off with the other foot to start gliding.

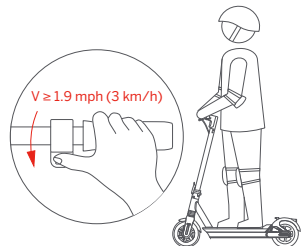

3

Put your other foot on the footboard to keep both feet stable. Press the throttle to speed up when you are balanced.



WARNING

When hard braking, you risk serious injury due to loss of traction and falls. Maintain a moderate speed and look out for potential hazards.

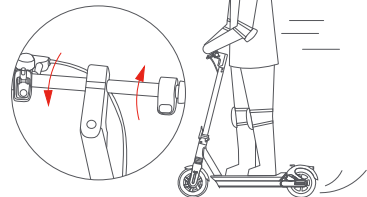

4

Slow down by releasing the throttle, and brake by squeezing the brake lever.
The rear light flashes when braking.

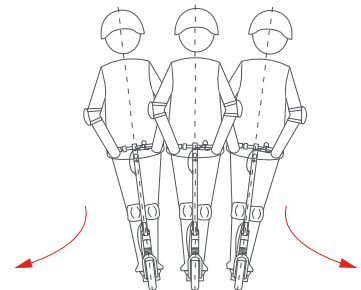

5

To turn, shift your body and turn the handlebar slightly.

8 WARNINGS

⚠ WARNING

Failure to follow these instructions could lead to serious injury.

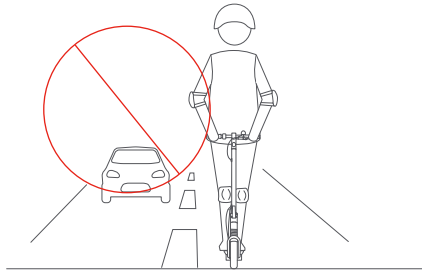

⚠ DO NOT ride on public roads, motorways, or highways.

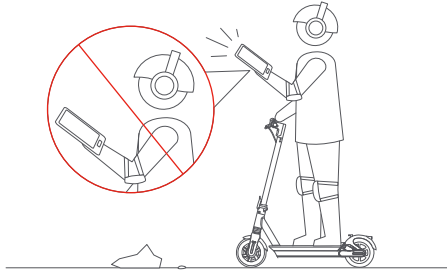

⚠ DO NOT use a mobile phone or wear earphones when riding the KickScooter.



⚠ DO NOT brake rapidly. Use both brakes together when traveling at fast speed.



⚠ Do not keep your feet on the rear fender.

Risk of fire and electric shock.

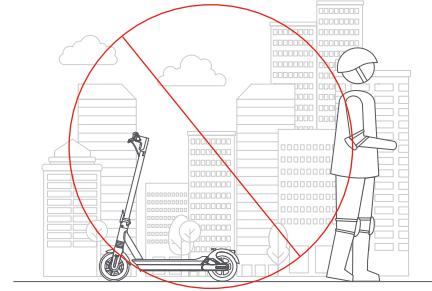

⚠ DO NOT park in open air or outdoors for a long time.

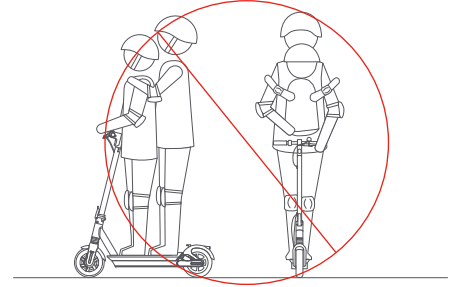

⚠ DO NOT carry any passengers.

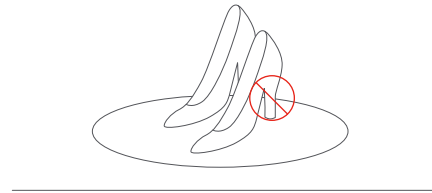

⚠ DO NOT wear high heels when riding.



⚠ DO NOT ride the KickScooter with only one foot or one hand.



DO NOT ride the KickScooter in the rain. DO NOT ride through puddles or other obstacles.

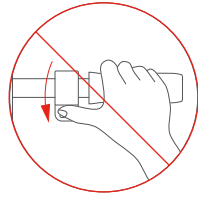

DO NOT press the throttle when walking with the KickScooter.

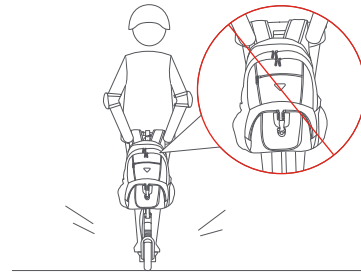
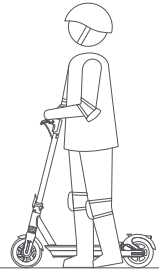

DO NOT carry heavy objects on the handlebar.

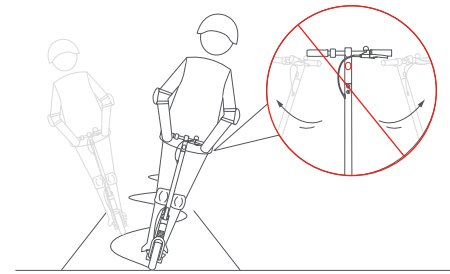

DO NOT rotate the handle violently while driving at high speed.

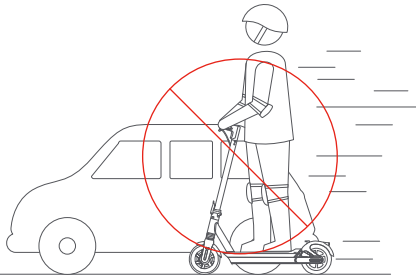

DO NOT overtake.

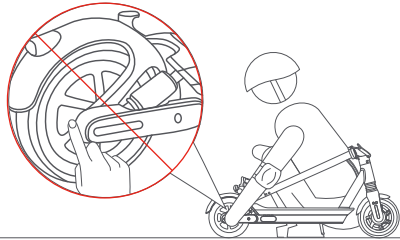

DO NOT touch the hub motor after riding because it can get hot.

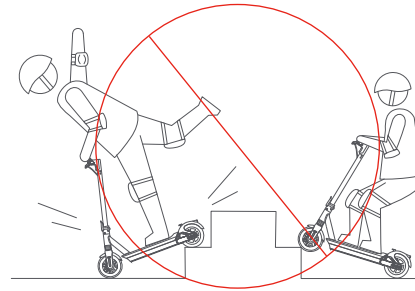

DO NOT ride up and down stairs or jump over obstacles.

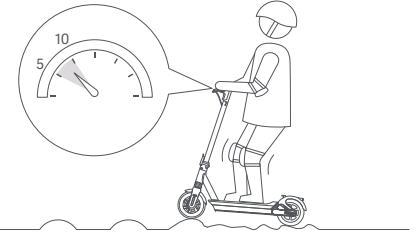

Keep your speed between 3.1–6.2 mph (5–10 km/h) when you ride through speed bumps, or other uneven surfaces.

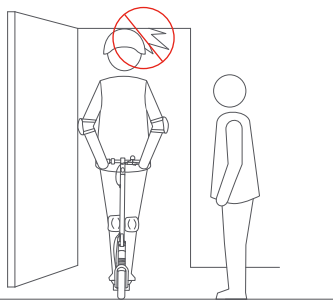

Watch your head when passing through doorways.

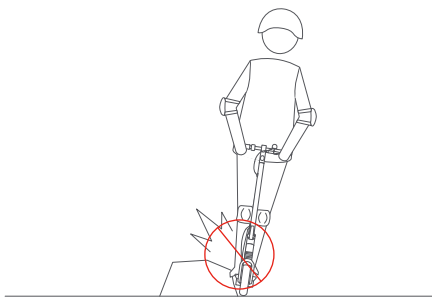

Avoid contacting obstacles with the tire/wheel.

Folding and Carrying

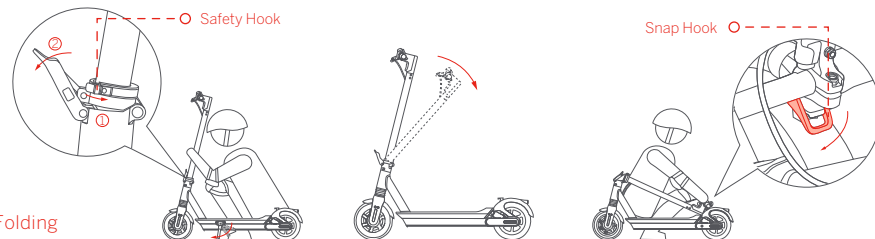

Folding

Release the safety hook, and push the quick-release lever down. Then fold the stem.

Align the snap hook and the buckle and hook them.

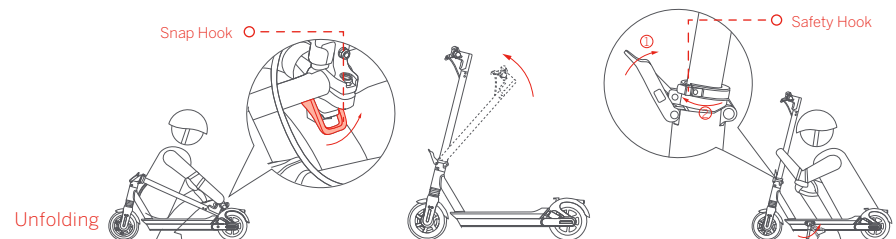

Unfolding

Disengage the snap hook from the buckle.

Unfold the stem. Close the quick-release lever, and lock with the safety hook. Then unfold the kickstand.

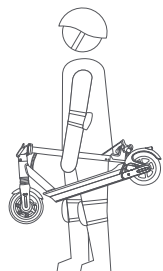

Carrying

When your KickScooter is folded up, lift it by the stem to carry.

Maintenance

Caution

- Be sure the KickScooter is powered off before performing any maintenance or when installing or replacing parts.
- When installing components, use proper and sufficient force until the component is secure. If the installation is too loose or too tight, the KickScooter may not function properly resulting in the potential for injury to you or others or damage to, or malfunction of, the KickScooter.
- DO NOT modify your KickScooter. Modifications to your KickScooter could interfere with the operation and performance of the KickScooter, which may result in serious injury and/or damage, and could void the Limited Warranty. Only use Ninebot or Segway approved parts and accessories.

Cleaning

Use a soft, wet cloth to wipe the mainframe clean. Dirt hard to remove can be scrubbed with a toothbrush and toothpaste, then cleaned with a soft, wet cloth.

WARNING

1. Make sure the KickScooter is powered OFF, the charge cable is unplugged, and the rubber cap on the charge port is tightly sealed before cleaning; otherwise you may expose yourself to electric shock or damage the electronic components.
2. DO NOT wash your KickScooter with alcohol, gasoline, acetone, or other corrosive/volatile solvents. These substances may damage the appearance and internal structure of your KickScooter.
3. DO NOT wash your KickScooter with a power washer. DO NOT use a strong water flow or high-pressure hoses to clean the KickScooter. Avoid getting water in the charge port. If your KickScooter has been exposed to heavy rain store it outdoors away from buildings and people but protected from the elements until it is dry.

Storage

Store your KickScooter indoors. DO NOT store it outdoors for extended periods. The KickScooter should be stored in an environment where the temperature is no higher than 122°F (50°C) or lower than 14°F (-10°C). If the temperature of the storage environment is lower than 32°F (0°C), DO NOT charge it until after placing it in a warm environment (over 50°F (10°C)).

WARNING

Exposure to sunlight and temperature extremes (both hot and cold) will accelerate the aging process of the plastic components and may reduce battery life.

Battery Maintenance

WARNING

1. Only use the battery specified by the manufacturer.
2. DO NOT store or charge the battery at temperatures outside the stated limits (see Specifications).
3. DO NOT puncture the battery. DO NOT attempt to disassemble the battery. DO NOT touch battery contacts. DO NOT dismantle or puncture the casing.

4. Keep the battery contacts away from metal objects to prevent short circuit. Risk of fire. No user serviceable parts.
5. DO NOT charge or use your battery if it is damaged or see a trace of water.
6. DO NOT store or charge the battery at temperatures outside the stated limits (see Specifications). DO NOT expose the battery to fire. DO NOT discard or destroy the battery.
7. Charge the battery after each ride and avoid draining the battery completely. Please read the user materials before charging the battery.
8. Refer to your local laws and regulations regarding battery recycling and/or disposal.

NOTE

1. When the scooter is powered off, it will still cause battery consumption. If the scooter is not in use for a long time, charge the battery to 50% or above before storage. It's recommended to charge the battery once every 30 to 60 days, or it may cause damage to the battery performance due to over-discharge. Electronics inside the battery record the charge-discharge condition of the battery, and any damage caused by over-charge or over-discharge will not be covered in the product warranty.
2. A well-maintained battery can perform well even after many miles of riding. When used at a room temperature (77°F [25°C]), its battery range and performance are at its best; whereas used at a temperature below 32°F (0°C), its battery range and performance may decrease. Typically, the battery range is affected by the temperature. The low temperature will reduce the battery range.
 - Only use the charger specified by the manufacturer. DO NOT use a charger from any other product.
 - DO NOT charge if the charge port or charge cable is wet.
 - DO NOT charge or use your battery if it is damaged or see a trace of water. Close the charge port cover when not charging.
 - DO NOT attempt to charge your KickScooter if the charger or the power outlet is wet.
 - DO NOT charge outdoors.

Valve Stem Extension

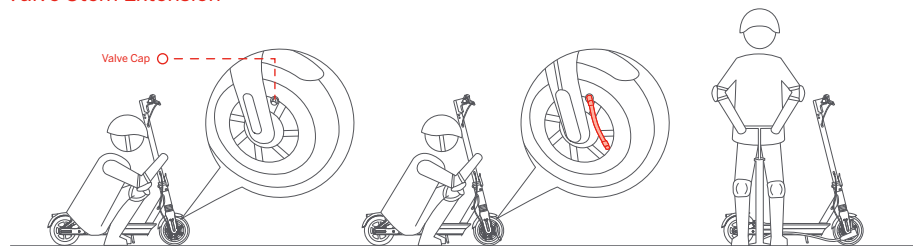

- 1 Unscrew the valve cap.
- 2 Connect the valve stem extension to the tire valve stem.
- 3 Connect the pump to inflate the tire.

Specifications

	Item	Parameter
Product	Name	Ninebot KickScooter MAX
	Model	G65E
	Length × Width × Height	Approx. 1190 × 520 × 1270 mm (46.9 × 20.5 × 50 in)
	Folded: Length × Width × Height	Approx. 1190 × 520 × 590 mm (46.9 × 20.5 × 23.2 in)
	Net Weight	Approx. 24.4 kg (53.8 lbs)
Rider	Max. Payload	120 kg (265 lbs)
	Recommended Age	16–60 years
	Required Height	120–200 cm (3'11"–6'6")
Machine	Max. Speed	Approx. 25 km/h (15.5 mph)
	Typical Range ⁽¹⁾	Approx. 65 km (40.4 miles)
	Max. Slope	Approx. 20%
	Traversable Terrain	Bicycle lanes, parks, campuses and most of the flat road conditions and typical Belgian roads
	Operating Temperature	-10–40°C (14–104°F)
	Storage Temperature	-10–50°C (14–122°F)
	IP Rating	IPX5
	Duration of Charging	Approx. 5 h
Battery	Nominal Voltage	36 V
	Max. Charging Voltage	42 V
	Charging Ambient Temperature	0–40°C (32–104°F)
	Nominal Capacity	15300 mAh
	Nominal Energy	551 Wh
	Battery Management System	Over-heating, short circuit, over-current, over-discharge and over-charge protection
Motor	Nominal Power	0.45 kW, 450 W
	Max. Power	0.6 kW, 600 W

	Item	Parameter
Charger	Output Power	Max. 121.8 W
	Input Voltage	100–240 V~ 50 / 60 Hz
	Output Voltage	42 V ===
	Output Current	2.9 A
	Type	Built-in
	Model	NB-42D0-02D9
Features	Brake Light	LED Rear Light
	Speed Modes	Energy-saving mode, Standard mode and Sport mode
Tire	Tire Pressure	40–45 psi
	Tires	10-inch self-sealing tubeless tire

[1] Typical Range: tested while riding with a full battery, 75 kg (165 lbs) load, 25°C (77°F), at the speed of 16 km/h (9.9 mph) on average on pavement.

* Some of the factors that affect range include speed, number of starts and stops, ambient temperature, etc.

Trademark and Legal Statement

Ninebot is the registered trademark of Ninebot (Beijing) Tech Co., Ltd; Powered by Segway, Segway and the Rider Design are the registered trademarks of Segway Inc.; Bluetooth is the trademark of BLUETOOTH SIG, INC.; Android, Google Play are trademarks of Google Inc.; App Store is trademark of Apple Inc.; The respective owners reserve the rights of their trademarks referred to in this manual.

The KickScooter is covered by relevant patents. For patent information, go to <http://www.segway.com>

We have attempted to include descriptions and instructions for all the functions of the KickScooter at the time of printing. However, due to constant improvement of product features and changes of design, your KickScooter may differ slightly from the one shown in this document. Visit the Apple App Store (iOS) or the Google Play Store (Android) to download and install the App.

Please note that there are multiple Segway and Ninebot models with different functions, and some of the functions mentioned herein may not be applicable to your unit. The manufacturer reserves the right to change the design and functionality of the KickScooter product and documentation without prior notice.

© 2022 Ninebot (Beijing) Tech Co. Ltd. All rights reserved.

IMPORTANT: The user shall agree to read the entire Important Information and the User Manual and fully understand their contents (especially the parts related to warnings and caution statements) and adhere to the instructions herein before riding this KickScooter.

1. This KickScooter can be dangerous to a user, other persons, and property in proximity to that. The user shall assume all the risks and losses in connection with the product (especially for those related to and/or arising out of violation of the instructions about warnings and caution statements). Such risks include but not limited to loss of control, failure of the product, and/or collusion) The consequences for such an incident can be severe, including but not limited to injuries, bodily injuries, death, and/or damages to property. Segway shall not be liable for any claim, liability, and loss related to such consequences if it is due to the user's assumption of risk.

- The user may not have necessary and sufficient experience and skills to ride the KickScooter, especially in complex environments and/or undesirable road and/or traffic conditions. Such risk may increase if the user has physical and/or mental impairment or disability, or a user is under the influence of alcohol, drugs or similar substance. Such risk may also increase if the user is not sufficiently familiar with the functions, features and performance of the KickScooter. Thus, the user, especially new users, shall learn and practice how to ride this KickScooter properly and safely. Experience accumulated by practice would normally enable a user to better ride and operate the KickScooter by time.
- The parts and components of the KickScooter are subject to fatigue, wear and tear ("Wear and Tear"). Many factors, such as environment, aging road conditions and/or riding behaviors may affect the rate of Wear and Tear. Wear and Tear may cause unanticipated and/or sudden failure of the KickScooter, which may cause, inter alia, severe bodily injury or even death. So, the user shall regularly and periodically, as the circumstance requires, inspect and maintain the KickScooter. The user shall also conduct reasonable examination and inspection of the KickScooter every time before riding it. For instance, every time before riding the KickScooter, the user shall check and examine tire performance, battery level, and all functional parts. If abnormality, discoloration or change of color of material (especially in an area that receives high stress when the KickScooter is in motion or junction), scratch, crack, loose fasteners, and/or missing parts (such as screw, bolts and/or nut) which strongly indicates that it is not safe to ride the KickScooter.
- Since it is impossible to predict and/or anticipate all and every scenario, condition, and/or circumstances under which a KickScooter user may be exposed to risk and danger, the Important Information and the User Manual are not intended to be an exhaustive list on how to ride the KickScooter safely and/or avoid hazards related to the KickScooter. In addition to adhere to the instructions, the user shall also ride and/or use the KickScooter with responsibility, carefulness, precaution, and best judgment. The user should always be a responsible rider, cautious, maintain proper speed and avoid all dangerous riding behaviors, as well as traffic and/or road conditions when riding the KickScooter. For instance, you shall avoid speeding, overloading or performing stunts of any kind. Do not try to touch the tires with your hands or feet while riding. The KickScooter is for one rider only.
- The user shall check and obey the local laws or regulations over the KickScooter. It is the sole user's responsibility that he/she shall ride, use and/or dispose of the KickScooter in compliance with the law. The law and regulations may be different in different jurisdictions. Apart from the others, such laws and regulation may include:
 - A helmet may be legally required by local law or regulation in your jurisdiction.
 - Vehicle registration and a license plate may be legally required by local law or regulation in your area.
 - Your KickScooter may not be allowed to be driven in motorway or highway.

You may obtain more information related to legal requirements on KickScooter from your local government.
- The users shall immediately check whether the KickScooter and its accessories are in good condition upon receipt of the KickScooter.
- All the separate components and parts of the KickScooter must be properly installed per the User Manual and the Important

Information. Inappropriate installation and/or assembly may significantly increase the risk of loss of control, product failure, collisions, and falls. The KickScooter may contain removable components and small parts. Please keep them out of the reach of children to avoid choking hazards.

8. Do not dispose of this KickScooter in a landfill, by incineration, or by mixing with household trash. Serious danger/ injury can occur because of the electrical components and the battery. For information about battery and electrical waste, please contact your household waste disposal service, your local or regional waste management office, or your point-of-sale. The user shall not use any non-original accessories or dismantle or modify the KickScooter without authorization. All damages, injuries, and damages to property arising from that place will be your sole responsibility and risk.
9. Segway reserves the right to make changes to the KickScooter, release firmware updates, and update this manual at any time. Segway may make improvements and changes to the User Manual or the Important Information necessitated by typographical errors, inaccuracies of current information, or modifications to programs and/or equipment at any time and without notice. Such changes will, however, be incorporated into new editions of this Important Information. All illustrations are for illustration purposes only and may not accurately depict the actual device. Actual KickScooter and functions may vary. Due to the update of the KickScooter, there may be some deviations in color, appearance, and other aspects between the KickScooter listed in this Important Information and the KickScooter you purchased. Please refer to the actual KickScooter.
10. This document should be considered as a permanent part of the KickScooter, and it shall be provided to the user together with the KickScooter all the time.

Limited Warranty

This Limited Warranty covers only defects of any material or quality of the Product and components when the Product and components thereof are being used under normal and ordinary conditions. In the event that a defect covered by this Limited Warranty occurs, Segway and/or other Segway Parties in its sole discretion will repair or replace the defective Product or components thereof in accordance with this Limited Warranty. The applicable Limited Warranty Period for the Limited Warranty commences on the date of the original purchase of the Product from either of Segway, Segway's authorized reseller, Segway's authorized distributor, or an authorized Dealer (each a "Segway Dealer" or collectively the "Segway Dealers").

Name of the Component	Limited Warranty Period
Frame Assembly Handlebar Stem Top Front Wheel Hub Assembly	3 years
Controller Dashboard Headset Main Control Cable Brake Cable Headlight Assembly Folding Stem Wheel Hub Motor Taillight	2 years
Battery Built-in Charger Brake Lever & Bell Twist-grip Throttle AC Cable Shock Absorber Drum Brake Front Fork Assembly	1 year

Name of the Component	Limited Warranty Period
Kickstand Front & Rear Fender Folding Hanger Charging Base Front Fork Cover Bumper Bar Decorative Cover Battery Compartment Cover Footpad Dashboard Cover Handlebar Grip Coded lock	180 days

THIS LIMITED WARRANTY HEREIN IS THE ONLY EXPRESS WARRANTY APPLICABLE TO PRODUCT AND ITS COMPONENT PARTS, ACCESSORIES, AND SERVICE REPAIR. SEGWAY AND SEGWAY PARTIES DISCLAIM ALL OTHER EXPRESS WARRANTIES. SEGWAY AND OTHER SEGWAY PARTIES LIMIT THE DURATION AND REMEDIES OF ALL IMPLIED WARRANTIES, INCLUDING WITHOUT LIMITATION TO THE WARRANTIES OF MERCHANTABILITY AND FITNESS FOR A PARTICULAR PURPOSE, WHETHER ARISING BY LAW, COURSE OF DEALING, COURSE OF PERFORMANCE, USAGE OF TRADE OR OTHERWISE, TO THE DURATION OF THIS EXPRESS LIMITED WARRANTY.

THIS LIMITED WARRANTY DOES NOT IN ANY WAY AFFECT OR LIMIT THE STATUTORY RIGHTS YOU MAY HAVE AS A CONSUMER, FOR EXAMPLE WITH RESPECT TO CONFORMITY.

13.2 Limited Warranty Eligibility

- 1) Your service request must be received by Segway within the Limited Warranty Period as described above, and Segway must receive your Product in accordance with the Limited Warranty Service Process defined above.
- 2) Your Product must be purchased from an authorized Segway Dealer.
- 3) You must provide the original purchase receipt.
- 4) Your Product must have serial number legible, unobscured, untampered, and unmodified.
- 5) All tamper-resistant seals must be intact, in place, and unmodified.

13.3 Limited Warranty Exclusions

This Limited Warranty describes the service available to you if your product requires warranty service, and you may have additional protections under your local laws. This Limited Warranty does not cover and excludes damage to your product or any component thereof caused by:

- 1) Abuse, misuse, recklessness, negligence, or commercial use.
- 2) Improper charging, storage, maintenance, or operation of the Product not in compliance with instructions or limitations as provided in the user materials.
- 3) Use of the Product not in compliance with applicable laws and regulations.
- 4) Use of the Product by persons with inadequate experience.
- 5) Accident, collision, riding at an unsafe speed on paved roads, riding at an unsafe speed on unpaved roads, riding over obstacles, amateur racing, professional racing, use in backcountry sports, fire damage, water damage, chemical damage, use of the Product outside of the Product's working temperature range, high-pressure water spray, earthquake, dropping, loading with excessive weights.
- 6) Modifications to mechanical parts, modification of electronic parts, or modifications to software embedded in the Product.
- 7) Service, repair, and maintenance by unauthorized providers.
- 8) Cosmetic damages.
- 9) Use of the Product with third party product, component, or accessory.
- 10) The normal deterioration of wear and tear parts.
- 11) Use of the Product with overdue wear and tear parts.

13.4 Liability Disclaimer and Limitation

- 1) Segway parties do not assume, or authorizes anyone to assume on its behalf, any other obligation or liability in connection with a Product, its component parts, accessories, service repair, or this Limited Warranty.
- 2) Segway parties and Segway dealers are not responsible for any loss of use of a Product, its component parts, accessories, or for any inconvenience or other loss or damage which might be caused from any defect in a Product, its component parts, accessories, service repair, or for any other incidental or consequential damages the purchaser may have as a result of any defect in a Product, its component parts, accessories, or service repair. SOME COUNTRIES DO NOT ALLOW THE EXCLUSION OR LIMITATION OF INCIDENTAL OR CONSEQUENTIAL DAMAGES, SO THE ABOVE LIMITATION OR EXCLUSION MAY NOT APPLY TO YOU TO THE EXTENT THAT IT IS DISALLOWED BY APPLICABLE LAW.
- 3) IN NO EVENT, SEGWAY PARTIES AND SEGWAY DEALERS' TOTAL AND AGGREGATE LIABILITY FOR ALL CLAIMS UNDER ANY AND ALL APPLICABLE LAW OR THEORY, JOINTLY OR SEVERALLY, ARISING OUT OF OR RELATED TO THE PURCHASE OF THE PRODUCT, USE OF THE PRODUCT, BREACH OF CONTRACT, TORTS (INCLUDING NEGLIGENCE) OR OTHERWISE, EXCEEDS THE DUTY TO REPAIR OR REPLACE ANY DEFECTIVE PRODUCT, FURTHER SUBJECT TO SEGWAY'S SOLE AND EXCLUSIVE DISCRETION. IN NO EVENT SHALL BE SEGWAY PARTIES AND

SEGWAY DEALERS BE LIABLE TO ANY PERSON FOR CONSEQUENTIAL, INDIRECT, INCIDENTAL, SPECIAL, EXEMPLARY, PUNITIVE OR ENHANCED DAMAGES ARISING OUT OF, OR RELATING TO, AND/OR IN CONNECTION WITH THE PURCHASE OF THE PRODUCT, ANY BREACH OF THIS AGREEMENT OR MANUFACTURER'S DUTIES REGARDLESS OF (A) WHETHER SUCH DAMAGES WERE FORESEEABLE, (B) WHETHER OR NOT SEGWAY OR OTHER SEGWAY PARTIES WERE ADVISED OF THE POSSIBILITY OF SUCH DAMAGES, AND (C) THE LEGAL OR EQUITABLE THEORY (CONTRACT, TORT OR OTHERWISE) UPON WHICH THE CLAIM IS BASED UNLESS SUCH LIMITATIONS AND EXCLUSIONS ARE PROHIBITED BY APPLICABLE LAW. THE FOREGOING LIMITATIONS OR EXCLUSIONS APPLY EVEN IF AN AGGRIEVED CUSTOMER OR ANY OTHER PERSON'S (WHO MIGHT HAVE RIGHT OR CLAIM UNDER THIS AGREEMENT BY OPERATION OF LAW OR EQUITY) REMEDIES UNDER THIS AGREEMENT FAIL THEIR ESSENTIAL PURPOSE. IN THE EVENT SOME COUNTRIES DO NOT ALLOW THE EXCLUSION OR LIMITATION OF CERTAIN OR ALL OF THE FOREGOING DAMAGES, SO TO THE EXTENT THAT SUCH LIMITATIONS OR EXCLUSIONS ARE NOT ALLOWED BY LAW, THEY MAY NOT APPLY TO YOU. SOME COUNTRIES DO NOT ALLOW THE EXCLUSION OR LIMITATION OF INCIDENTAL OR CONSEQUENTIAL DAMAGES, SO TO THE EXTENT THAT SUCH LIMITATIONS OR EXCLUSIONS ARE NOT ALLOWED BY LAW, THE ABOVE LIMITATION OR EXCLUSION MAY NOT APPLY TO YOU.

- 4) To the extent permitted by applicable law, SEGWAY PARTIES and SEGWAY DEALERS hereby DISCLAIM any liability and thereby shall not be responsible for any damages, including but not limited to death, bodily injury, or damages to property, arising out of or related to any conduct (including misconduct), action, inaction, act (including failure to act), omission or negligence by any authorized or unauthorized dealer, distributor, wholesaler, retailer, service provider or third party that involves into the distribution of Product or the services thereto. To the extent permitted by applicable law, the explicit representations and warranties, if any, provided herein, shall be the only warranties and representations made by SEGWAY PARTIES to YOU, any consumer, and/or end-user. and SEGWAY PARTIES shall not be responsible for any other warranties and/or representations that may be given and/or provided by another person unless SEGWAY PARTIES have in a written form explicitly authorized such additional warranty and/or representation to be given to consumer or end-user.

13.5 Claims, Dispute Resolution and Arbitration

THE CLAUSES CONTAINED HEREIN ARE LEGALLY BINDING BETWEEN YOU, SEGWAY PARTIES AND SEGWAY DEALERS. THE CLAUSES CONTAINED HEREIN MAY AFFECT YOUR RIGHTS, AND IT IS YOUR RESPONSIBILITY TO READ THE FOLLOWING SECTIONS. YOU CAN OPT OUT OF THE AGREEMENT WITHIN 30 CALENDAR DAYS OF THE FIRST CONSUMER PURCHASE BY EMAILING OPTOUT@SEGWAY.COM AND PROVIDING THE APPLICABLE INFORMATION. FOR MORE DETAILS, PLEASE SEE SECTION 6.2.

1) **Binding Arbitration**

Segway Parties, Segway Dealers and you agree that any dispute, controversy or claim arising out of, relating to or in connection with this agreement, the limited warranty, the sale, condition or performance of the product, whether based in contract, tort, fraud, misrepresentation, or any other legal theory at law or in equity, including but not limited

to any claims for death, injury or property damages, shall be governed by and construed in accordance with the laws of the Netherlands with the exclusion of its conflicts of law provisions, and finally resolved by the International Chamber of Commerce (ICC) under the 2021 ICC Rules of Arbitration (ICC Rules) for the time being in force, which Rules are deemed to be incorporated by reference into this clause. Further the Parties agree that:

i. The seat of the arbitration shall be Amsterdam, Netherlands.

ii. The Tribunal shall consist of 3 arbitrator(s).

iii. The language of the arbitration shall be English.

Section 6 "Claims, Dispute Resolution and Mandatory Arbitration" clause shall survive upon termination or expiration of this agreement and/or limited warranty or in an event that this agreement and/or the limited warranty is held as void, avoidable, invalid, or unenforceable, either in whole or part, by a competent adjudication institution with actual authority and jurisdiction over this matter.

2) **Opt-Out**

YOU MAY OPT OUT OF THIS DISPUTE RESOLUTION PROCEDURE BY PROVIDING NOTICE TO SEGWAY or SEGWAY PARTIES NO LATER THAN THIRTY (30) CALENDAR DAYS AFTER THE DATE OF THE FIRST CONSUMER PURCHASER'S PURCHASE OF THE PRODUCT. TO OPT-OUT, YOU MUST SEND NOTICE BY EMAIL AT OPTOUT@SEGWAY.COM, WITH THE SUBJECT LINE: "ARBITRATION OPT-OUT." THE OPT-OUT NOTICE BY E-MAIL MUST INCLUDE (A) YOUR NAME, EMAIL ADDRESS, MAILING ADDRESS, AND PHONE NUMBER; (B) THE DATE ON WHICH THE PRODUCT WAS PURCHASED; (C) THE PRODUCT MODEL NAME OR MODEL NUMBER; AND (D) THE SERIAL NUMBER. ALTERNATIVELY, YOU MAY OPT OUT BY SENDING AN ELECTION TO OPT-OUT LETTER TO SEGWAY AT Dynamostraat 7, 1014BN, Amsterdam, The Netherlands. CERTIFIED MAIL WITHIN THIRTY (30) CALENDAR DAYS FROM THE DATE OF THE FIRST END USER'S PURCHASE OF THE PRODUCT FROM SEGWAY DEALER. THE OPT-OUT LETTER SHALL CONTAIN THE FOLLOWING INFORMATION: (A) YOUR NAME, EMAIL ADDRESS, MAILING ADDRESS, AND PHONE NUMBER; (B) THE DATE ON WHICH THE PRODUCT WAS PURCHASED; (C) THE PRODUCT MODEL NAME OR MODEL NUMBER; (D) THE SERIAL NUMBER; AND (E) AN STATEMENT AS FOLLOWS: THE ABOVE CONSUMER ELECTS TO OPT-OUT THE DISPUTE RESOLUTION PROCEDURE AS PROVIDED BY THIS LIMITED WARRANTY. THESE ARE THE ONLY TWO EFFECTIVE WAYS TO OPT-OUT THIS DISPUTE RESOLUTION PROCEDURE. ELECTION TO OPT-OUT THIS DISPUTE RESOLUTION PROCEDURE WILL NOT AFFECT THE COVERAGE OF THE LIMITED WARRANTY IN ANY WAY, AND YOU WILL CONTINUE TO ENJOY THE BENEFITS OF THE LIMITED WARRANTY.

3) **Language**

This Agreement may be translated into different languages. In the event of a conflict, the English version shall prevail and control.