



XIAOMI Truclean W10 Ultra Wet Dry Vacuum User Manual •





Safety Instructions

This product is for household use only. Read this manual carefully before use, and retain it for future reference.

- This appliance can be used by children aged from 8 years and above and persons with reduced physical, sensory or mental capabilities or lack of experience and knowledge if they have been given supervision or instruction concerning use of the appliance in a safe way and understand the hazards involved. Children shall not play with the appliance. Cleaning and user maintenance shall not be made by children without supervision.
- This appliance contains batteries that are only replaceable by skilled persons.
- The appliance is only to be used with the power supply unit provided with the appliance.
- This vacuum is for indoor use only. Do not use or install it in outdoor, industrial, or commercial environments. Do not use the base station in humid environments such as bathrooms.
- Do not touch the plug or any part of the vacuum with wet hands.
- A hazard may occur if the appliance runs over the supply cord.
- The plug must be removed from the socket-outlet before cleaning or maintaining the appliance.
- If the power cord is damaged, it must be replaced by a special cord or assembly available from the manufacturer or its service agent.
- To reduce the risk of fire, explosion, or personal injury, check before use to make sure the lithium battery and power cord are undamaged. Do not use the vacuum if either the lithium battery or power cord is damaged.
- The main body and the floor brush of the vacuum are electrically conductive and should not be immersed in water or other liquids.
- Clean the dirty water tank in time to avoid the decrease of suction and overheating of the motor caused by obstruction. Otherwise, the service life of the vacuum may be affected. Do not use the vacuum if the roller brushbar, the dirty water tank, and the filter are not installed in place.
- Do not lift the vacuum when adding water to it at the base station.
- Make sure to turn off the vacuum before replacing the roller brushbar.
- Neither use the vacuum to pick up flammable or explosive liquids such as gasoline, nor other liquids such as water or toxic liquids like bleach, ammonia, and drain cleaners.
- Do not use the vacuum to clean up toner used in laser printers and copiers, as toner may cause fire or explosion.
- Do not use the vacuum to pick up smoking or burning materials such as charcoal, cigarette butts, or matches.
- Do not use the vacuum to pick up sharp or hard objects, such as glass, nails, screws, or coins, which may damage the vacuum.
- Do not use the vacuum to clean stains of thick oily substances, strong adhesives, or dyes, such as shoe polish, paints, and pigments.
- Keep hair, loose clothing, fingers, and other parts of the body away from the vacuum's openings and moving parts.
- Do not put any object into the vacuum's openings, nor use the vacuum with any opening blocked. Keep free of dust, lint, hair, or other items which may reduce airflow.
- Do not shake the vacuum up and down or hit it violently to prevent dirty water from flowing into the motor.
- Do not lift or move the vacuum while the motor is operating, nor tilt it to one side or lay it flat to prevent dirty water from entering the motor.
- Do not place the vacuum on unstable surfaces such as chairs or tables to prevent damage or personal injury caused by its falling off. If the vacuum malfunctions because of being knocked over or damaged, please contact the authorized service department. Never attempt to disassemble the vacuum on your own.
- Do not block the drying air outlet on the base station to avoid malfunctions.
- After washing the cleaning tray and the accessory container clean, thoroughly dry them before reinstalling them to the base station.
- After cleaning the roller brushbar, the filter, and the cleaning brush, thoroughly dry them before putting them into the accessory container to prevent odors.





- Do not rinse the base station with water.
- Use clean tap water when adding water to the water tank of the base station.
- Do not charge or store the vacuum near heat sources or in humid areas, such as by a radiator or in a kitchen or bathroom.
- Only use replacement parts that are approved by Xiaomi.
- Do not repair the vacuum on your own when it breaks down or has problems like electric leakage, overheating motor, making unusual sounds, overheating main body, giving off bad odors, or weak suction.
- Please be extra careful when using the vacuum to clean stairs.
- Do not apply any type of fragrance to the vacuum's filter. These types of products are known to contain flammable chemicals which may cause the vacuum to catch fire.
- Strictly follow the instructions in this user manual to charge the vacuum at an ambient temperature of 5°C to 40°C. Improper charging may result in damage to the battery.
- Please strictly follow the instructions in this user manual when using the vacuum. Users are responsible for any loss or damage that may arise from improper use of the vacuum.
- For detailed e-manual, please go to www.mi.com/global/service/userguide.

WARNINGS:

- The base station can only be used to dry the roller brushbar, the filter, and the cleaning brush of this vacuum.
- Do not use any third-party battery or power cord. Only use the B305GL-JZ base station provided with the appliance.

Regulatory Compliance Information



EU Declaration of Conformity

We, Beijing Shunzao Technology Co., Ltd., hereby declare that this equipment is in compliance with the applicable Directives and European Norms, and amendments. The full text of the EU declaration of conformity is available at the following internet address: <http://www.mi.com/global/service/support/declaration.html>



WEEE Disposal and Recycling Information

All products bearing this symbol are waste electrical and electronic equipment (WEEE as in directive 2012/19/EU) which should not be mixed with unsorted household waste. Instead, you should protect human health and the environment by handing over your waste equipment to a designated collection point for the recycling of waste electrical and electronic equipment, appointed by the government or local authorities. Correct disposal and recycling will help prevent potential negative consequences to the environment and human health. Please contact the installer or local authorities for more information about the location as well as terms and conditions of such collection points.



Product Overview

Vacuum

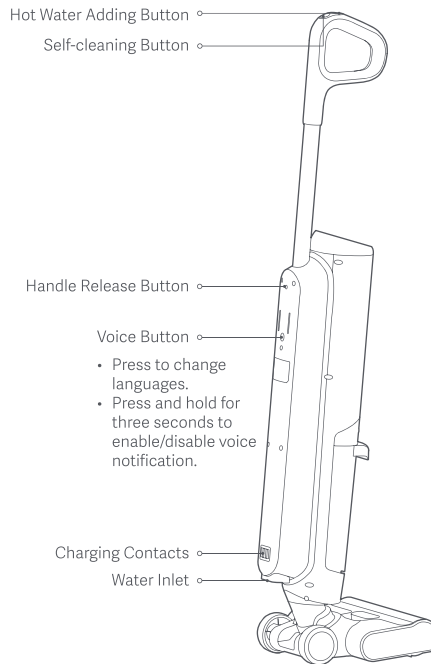
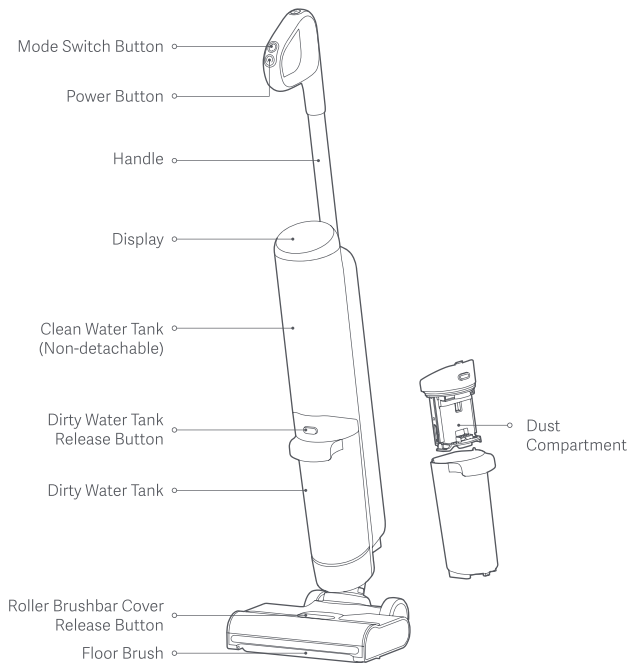



Accessory List

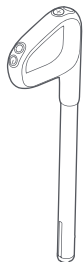

Handle

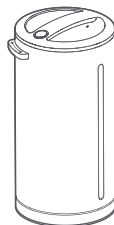

Water Tank



Cleaning Brush
(Rotate the handle of the cleaning brush to remove the blade)



Roller Brushbar
(Replacement) × 1



Filter
(Replacement) × 1



Power Cord

Note: Illustrations of product, accessories, and user interface in the user manual are for reference purposes only. Actual product and functions may vary due to product enhancements.





Installing the Base Station

1. Place the base station against a wall, and connect the power cord to it. Store the power cord in the back of the base station.

Note:

Do not place the vacuum and the base station near heat sources or in humid areas, such as by a radiator, in a kitchen, or in a bathroom.

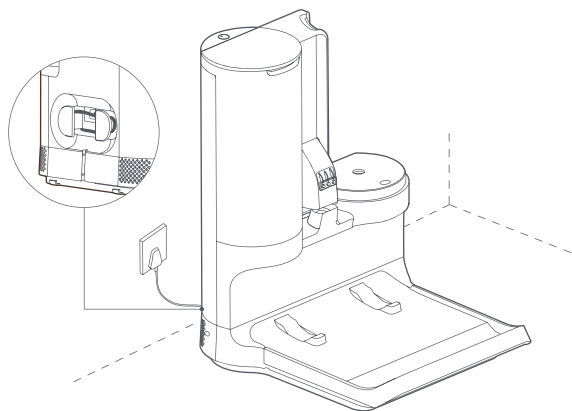

2. Press and hold the release button on the water tank cover and simultaneously rotate the cover to open it. Then add clean tap water to the water tank up to the maximum water level mark and install the cover back. It is secured in place when you hear a click.

Note:

Do not add any liquid other than tap water to avoid potential danger.

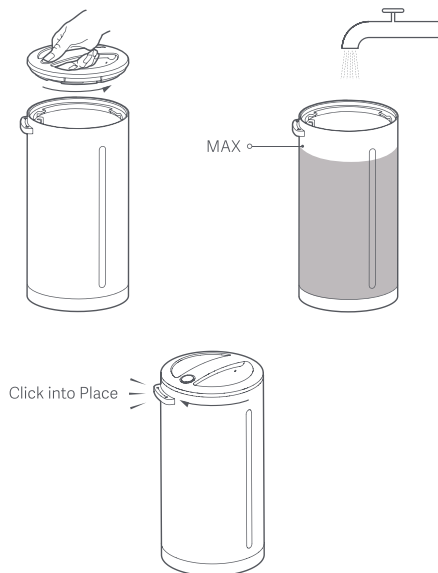



3. Put the water tank onto the base station. Open the accessory compartment, and place the spare roller brushbar, the spare filter, and the cleaning brush into the compartment.

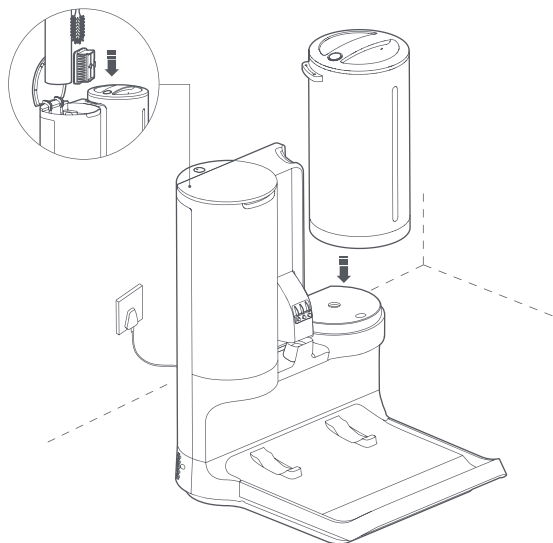

4. After the base station is powered on, place the vacuum on it to charge.

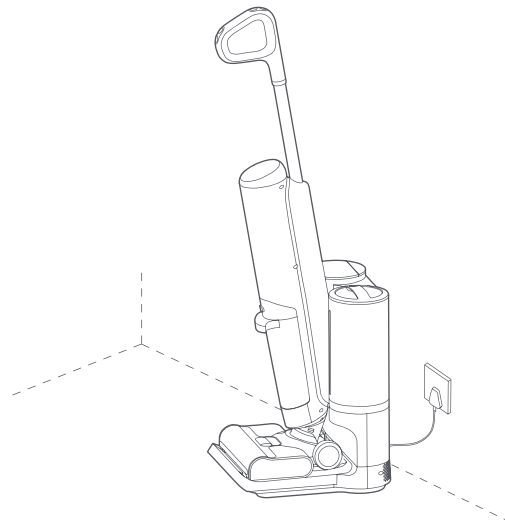

Notes:

- Fully charge the vacuum before first use and after each use. The total charging time is about 5 hours.
- Once the vacuum is fully charged, the display will turn off after 20 seconds and the vacuum will then enter the energy-saving mode.
- Working at the turbo mode for a prolonged period will cause the battery to heat up, and the charging time may increase or the battery level may not grow in a short time during charging. This is normal.



Charging

Battery Level Display

1. Place the vacuum on the base station, and the vacuum will begin charging. The display will go out 20 seconds after the vacuum is fully charged.
2. The number on the display represents the current battery level in a percentage during charging. The display will go out 20 seconds after charging is completed.
3. The vacuum cannot be charged when it is in the process of water adding, self-cleaning, or drying.

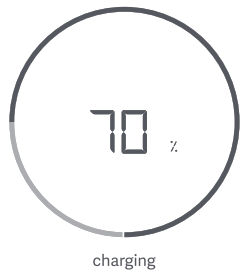

How to Use

Display and Buttons Instructions

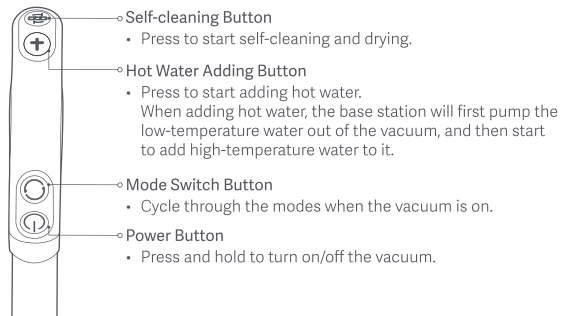
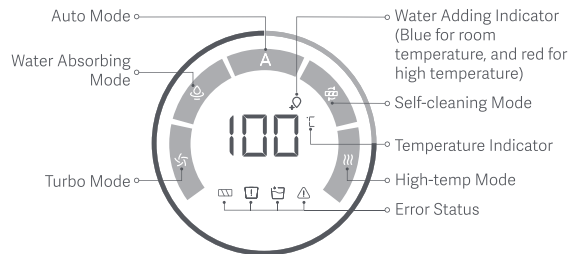



Using Scenarios

The vacuum can be used to clean different types of hard-surface flooring such as wood, tile, and marble.

- When the vacuum is working, the number on the display represents the temperature of water in the clean water tank.
- After adding hot water to the vacuum, the temperature of the water in the clean water tank may be different from the temperature of the roller brushbar surface. This is affected by the factors including operating environment, the temperature of water in the base station's water tank, the flooring material, and the heat loss in water pipelines.

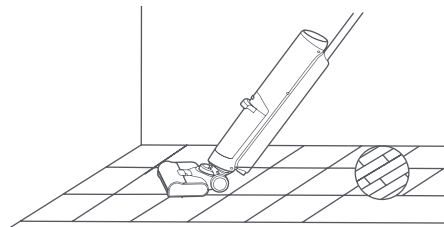

Do not use the vacuum on fabric surfaces, such as carpets and blankets.

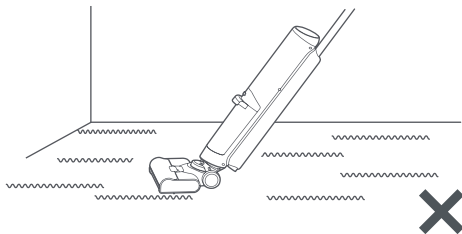

Water Adding

- When the vacuum is placed on the base station, the room temperature mode will be enabled and the base station will automatically add room temperature water to the vacuum.
- Press the button **+** to enable the high-temp mode. Once this mode is enabled, the base station will first pump the low-temperature water out of the vacuum, and then start to add high-temperature water to it.
- Do not remove the vacuum from the base station during water adding. Press the button **+** or **⏻** to stop adding water.
- The water tank indicator will change its color based on the water level. White indicates sufficient water, yellow indicates low water level, and red indicates insufficient water.

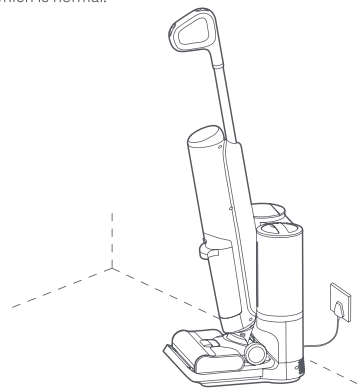

Notes:

- Due to the nature of the heating components, the first two heating temperatures may be a little lower. The water will be heated properly afterward.
- When heating water, the base station may make a sound similar to boiling water, which is normal.





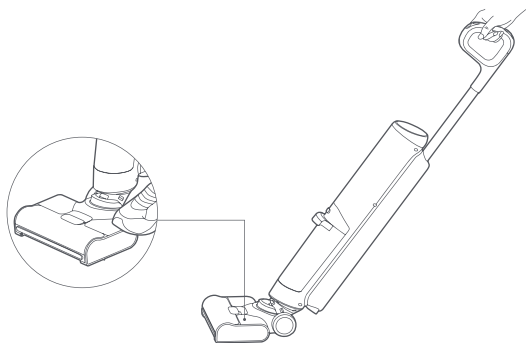

Cleaning the Floor

1. Remove the vacuum from the base station, step on the floor brush with one foot and pull back the handle to tilt the vacuum. Press and hold the button  to turn on the vacuum.
2. Press the button  to cycle through the modes of auto, water absorbing, and turbo.
3. After using the vacuum, press and hold the button  to turn off the vacuum. To avoid residual dirty water, the vacuum will continue to run for a few seconds before turning off.
4. Put the vacuum back onto the base station properly after using it. Do not place the vacuum against a wall to prevent it from tipping over due to improper placement.



Auto Mode	Water Absorbing Mode	Turbo Mode
Daily stains cleaning	Water stains cleaning	Stubborn stains cleaning (Combined with high-temp mode for better results)

Self-cleaning

1. Place the vacuum properly on the base station and press the button  to start self-cleaning. During drying, the roller brushbar will consume the vacuum's power to rotate and the vacuum cannot be charged. After the drying is completed, the vacuum will automatically start charging.
2. To stop self-cleaning or drying, press the button  or .

Note:

Clean the dirty water tank in time after self-cleaning to prevent odors.

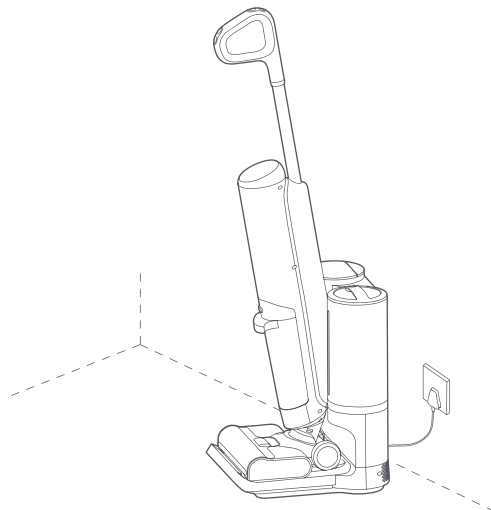



Drying the Accessories

1. Press the accessory drying button to enable/disable the accessory drying function.
2. During drying, the LED indicator will breathe white and go out when the drying is completed.
3. To prevent odors, clean the roller brushbar, the filter, and the cleaning brush and thoroughly dry them before putting them back in the accessory compartment.

Note:

The accessory drying function is for drying the filter and the cleaning brush. To dry the roller brushbar, use the drying function of the self-cleaning.

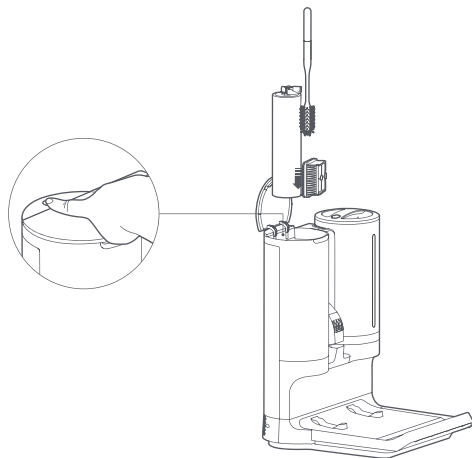

Cleaning the Dirty Water Tank

1. To remove the dirty water tank, press the release button on the dirty water tank and simultaneously pull the dirty water tank outwards.

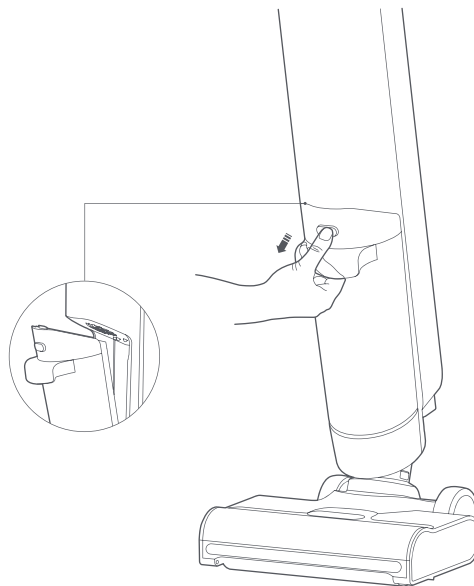



2. Pull the filter and the dust compartment upwards to remove them, and empty the dirty water out of the tank.

Note:

When removing the dust compartment, do not press the dirty water tank release button to prevent waste from falling out.

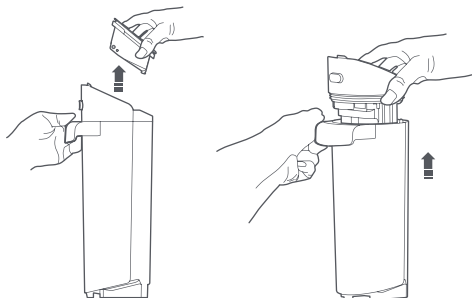

4. Rinse the dirty water tank, the dust compartment, and the filter with tap water until they are clean.

Notes:

- Put the filter into the accessory compartment to dry it after each clean.
- The cleaning brush can be used to assist in cleaning.

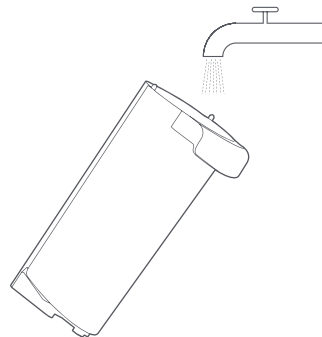

3. Press the dirty water tank release button to empty the dust compartment.

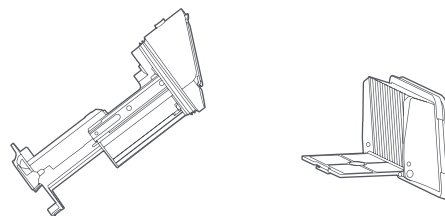
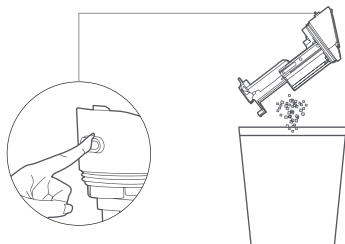



Cleaning the Floor Brush

1. Pull the roller brushbar cover release button outwards to take out the roller brushbar cover, and remove the roller brushbar upwards.

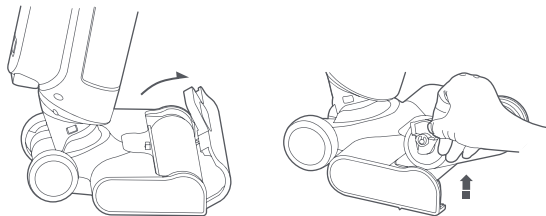

2. Rotate the handle of the cleaning brush to remove the blade. Use the blade to cut the hair tangled on the roller brushbar.

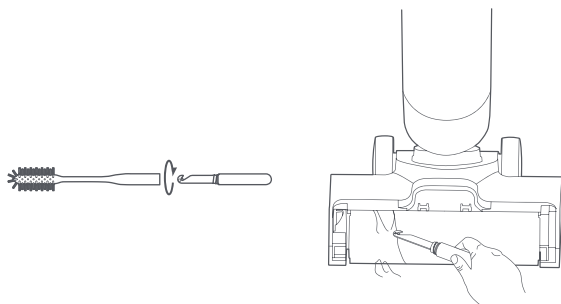

3. Use tap water to rinse the roller brushbar and its cover until they are clean.

Note:

Do not rinse the floor brush directly.

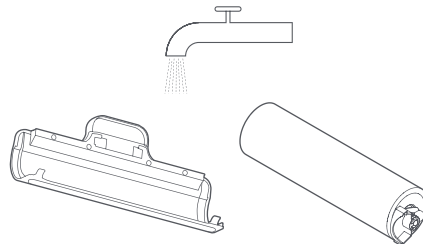

4. Use a dry cloth or paper towel to remove the hair, dirt, and foreign objects blocked at the suction port.

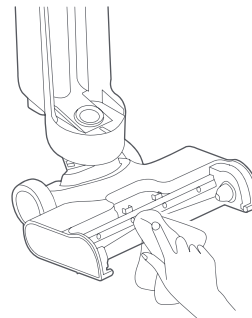



5. Reinstall the roller brushbar and its cover.

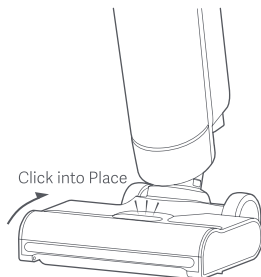
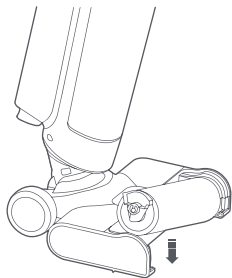

Cleaning the Cleaning Tray

1. Remove the cleaning tray from the base station and use tap water to rinse the tray until it is clean.

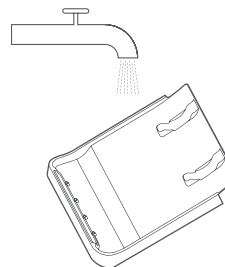
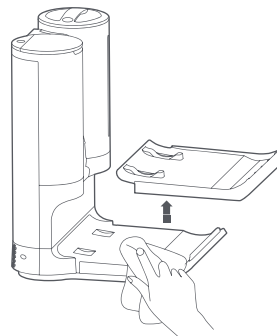



Cleaning the Accessory Compartment

1. Take out all the accessories stored in the accessory compartment, and lift the accessory container to remove it.

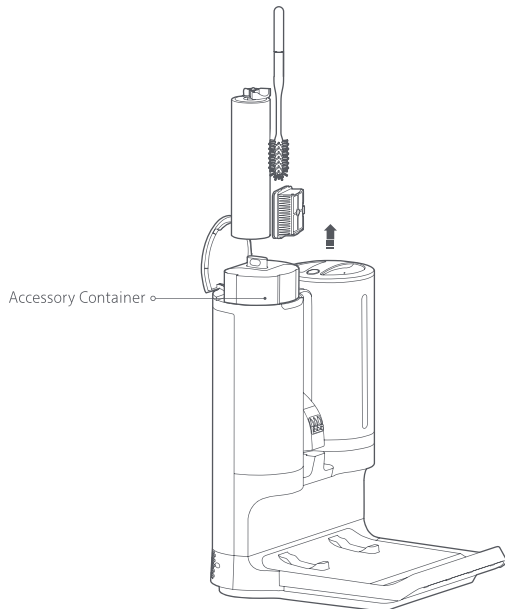

2. Clean the accessory container under tap water with the cleaning brush until the container is clean.

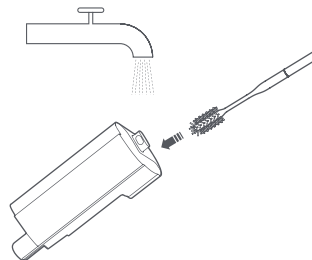

3. Thoroughly dry the accessory container and the accessories before putting them back in the accessory compartment.

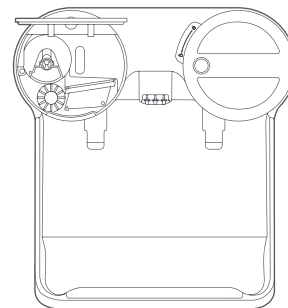



Common Issue





Error	Possible Cause	Solution
The vacuum does not work.	The battery is depleted.	Fully charge the vacuum before use.
	The battery has overheating protection.	Try again after the battery temperature returns to normal.
	The dirty water tank or the roller brushbar is not installed.	Properly install the dirty water tank and the roller brushbar.
	The dirty water tank is full.	Clean the dirty water tank and reinstall it.
	The clean water tank is out of water.	Put the vacuum on the base station to add water.
	The floor brush or the pipeline of the dirty water tank is blocked.	Clean the floor brush and the pipeline.
	The roller brushbar is clogged.	Clean the roller brushbar.
The vacuum cannot be charged.	The vacuum is working.	The vacuum cannot be charged in the process of water adding, self-cleaning, or drying. After the process is completed, the vacuum will automatically start charging.
	The base station is not plugged in.	Use the original power cord to charge the base station.
	The power cord used is not original.	Use the original power cord.
	The vacuum is not placed properly on the base station.	After putting the vacuum back to the base station, check the vacuum's position to make sure it is put in place.
The vacuum has no voice notification.	The voice notification is disabled.	Press and hold the voice button for three seconds to enable voice notification.
The vacuum cannot add water.	The base station's water tank is out of water.	Add an adequate amount of tap water.
	The base station is not plugged in.	Use the original power cord to charge the base station.
The vacuum cannot carry out self-cleaning.	The dirty water tank is full.	Clean the dirty water tank and reinstall it.
	The dirty water tank is not installed.	Reinstall the dirty water tank.
	The battery is low or depleted.	Carry out self-cleaning when the battery level is sufficient.





Troubleshooting

If the vacuum is not working properly, the display will show an error message. Please refer to the troubleshooting table to find your solution based on the error message.

Error Icon	Error Message	Solution
	The roller brushbar is tangled.	Remove any foreign objects clogged or tangled on the roller brushbar.
	The vacuum has run out of water.	Put the vacuum on the base station to add water.
	The dirty water tank is full.	Clean the dirty water tank and reinstall it.
	The dirty water tank is not installed in place.	Reinstall the dirty water tank.
	The roller brushbar is not installed in place.	Reinstall the roller brushbar.
	The pipeline is blocked.	Unblock the suction port of the floor brush and the pipeline of the dirty water outlet.
	The dirt detection sensor is dirty.	Wipe off dirt from the surface of the sensor with the cleaning brush.
	The vacuum malfunctions, and it has voice alert with error code.	Contact the after-sales service team to arrange maintenance.

Specifications

Xiaomi Truclean W10 Ultra Wet Dry Vacuum			
Name	Wet and Dry Vacuum Cleaner	Model	B305GL
Rated Voltage	21.6 V \approx	Rated Power	220 W
Charging Voltage	28 V \approx	Net Weight (Vacuum)	5.2 kg
IP Class	IPX4	Net Weight (with Accessories)	11.2 kg
Xiaomi Truclean W10 Ultra Wet Dry Vacuum Base Station			
Name	Base Station	Model	B305GL-JZ
Rated Input	220-240 V- 50/60 Hz	Rated Power	2100 W
Charging Output	28 V \approx 1.0 A	Net Weight	5.5 kg





Steps to Remove the Battery

The lithium-ion battery pack contains substances that are hazardous to the environment. Before disposing of the vacuum, please first remove the battery pack, then discard, or recycle it in accordance with local laws and regulations of the country or region it is used in.

CAUTION:

- Remove the entire battery pack together, and make sure not to damage the outer casing of the battery pack to prevent short-circuiting or leakage of harmful substances. In the event of a battery leak, avoid contact with the liquid. If the liquid enters the eyes, rinse with plenty of water and seek medical attention immediately.
- The battery should not be removed by non-professionals. Otherwise, it may lead to a short circuit or other risks. It is recommended to send the product to the professional after-sales service team or a government-approved recycling facility for removal.

Steps to Remove the Battery:

1. To remove the handle, insert a screwdriver into the hole on the back of the vacuum to press the handle release button, and simultaneously pull the handle upwards vertically.
2. Remove the dirty water tank and use a screwdriver to unscrew the rear shell of the vacuum.
3. Remove the rear shell, and unplug the battery to remove it.

WARRANTY NOTICE

THIS WARRANTY GIVES YOU SPECIFIC RIGHTS, AND YOU MAY HAVE OTHER RIGHTS CONVEYED BY LAWS OF YOUR COUNTRY, PROVINCE OR STATE. INDEED, IN SOME COUNTRIES, PROVINCES OR STATES, CONSUMER LAW MAY IMPOSE A MINIMUM WARRANTY PERIOD. OTHER THAN AS PERMITTED BY LAW, XIAOMI DOES NOT EXCLUDE, LIMIT OR SUSPEND OTHER RIGHTS YOU MAY HAVE. FOR A FULL UNDERSTANDING OF YOUR RIGHTS WE INVITE YOU TO CONSULT THE LAWS OF YOUR COUNTRY, PROVINCE OR STATE.

1. LIMITED PRODUCT WARRANTY

XIAOMI warrants that the Products are free from defects in materials and workmanship under normal use and use in accordance with the respective Product user manual, during the Warranty Period.

The duration and conditions related to the legal warranties are provided by respective local laws. For more information about the consumer warranty benefits, please refer to Xiaomi's official website <https://www.mi.com/en/service/warranty/>.

Xiaomi warrants to the original purchaser that its Xiaomi Product will be free from defects in materials and workmanship under normal use in the period mentioned above. Xiaomi does not guarantee that the operation of the Product will be uninterrupted or error free.

Xiaomi is not liable for damages arising from non-compliance with the instructions related to the use of the Product.

2. REMEDIES

If a hardware defect is found and a valid claim is received by Xiaomi within the Warranty Period, Xiaomi will either (1) repair the product at no charge, (2) replace the product, or (3) refund the Product, excluding potential shipping costs.

3. HOW TO OBTAIN WARRANTY SERVICE



To obtain warranty service, you must deliver the Product, in its original packaging or similar packaging providing an equal degree of Product protection, to the address specified by Xiaomi. Except to the extent prohibited by applicable law, Xiaomi may require you to present proofs or proof of purchase and / or comply with registration requirements before receiving warranty service.

4. EXCLUSIONS AND LIMITATIONS

Unless otherwise stipulated by Xiaomi, this Limited Warranty applies only to the Product manufactured by or for Xiaomi and identifiable by the trademarks, trade name or "Xiaomi" or "Mi" logo.

The Limited Warranty does not apply to any (a) Damage due to acts of nature or God, for example, lightning strikes, tornadoes, flood, fire, earthquake or other external causes; (b) Negligence; (c) Commercial use; (d) Alterations or modifications to any part of the Product; (e) Damage caused by use with non-Xiaomi products; (f) Damage caused by accident, abuse or misuse; (g) Damage caused by operating the Product outside the permitted or intended uses described by Xiaomi or with improper voltage or power supply; or (h) Damage caused by service (including upgrades and expansions) performed by anyone who is not a representative of Xiaomi.

It is your responsibility to backup any data, software, or other materials you may have stored or preserved on the product. It is likely that the data, software or other materials in the equipment will be lost or reformatted during the service process, Xiaomi is not responsible for such damage or loss.

No Xiaomi reseller, agent, or employee is authorized to make any modification, extension, or addition to this Limited Warranty. If any term is held to be illegal or unenforceable, the legality or enforceability of the remaining terms shall not be affected or impaired.

Except as prohibited by laws or otherwise promised by Xiaomi, the after-sales services shall be limited to the country or region of the original purchase.

Products which were not duly imported and/or were not duly manufactured by Xiaomi and/or were not duly acquired from Xiaomi or a Xiaomi's official seller are not covered by the present warranties. As per applicable law you may benefit from warranties from the non-official retailer who sold the product. Therefore, Xiaomi invites you to contact the retailer from whom you purchased the product.

The present warranties do not apply in Hong Kong and Taiwan.

5. IMPLIED WARRANTIES

Except to the extent prohibited by applicable law, all implied warranties (including warranties of merchantability and fitness for a particular purpose) will have a limited duration up to a maximum duration of this limited warranty. Some jurisdictions do not allow limitations on the duration of an implied warranty, so the above limitation will not be applied in these cases.

6. DAMAGE LIMITATION

Except to the extent prohibited by applicable law, Xiaomi shall not be liable for any damages caused by accidents, indirect, special or consequential damages, including but not limited to loss of profits, revenue or data, damages resulting from any breach of express or implied warranty or condition, or under any other legal theory, even if Xiaomi has been informed of the possibility of such damages. Some jurisdictions do not allow the exclusion or limitation of special, indirect, or consequential damages, so the above limitation or exclusion may not apply to you.

7. XIAOMI CONTACTS

For customers, please visit the website: <https://www.mi.com/en/service/warranty/>

The contact person for the after-sale service may be any person in Xiaomi's authorized service network, Xiaomi's authorized distributors or the final vendor who sold the products to you. If in doubt please contact the relevant person as Xiaomi may identify.